

## Chapter II Property Details

### A. Land Requirement:

Institute Under: Tier I:  Tier II:  Other:

(Refer from Schedule I)

Sr.	Intake Capacity	Land Requirement (in Acres)			Land Available in Acres	Adequate/Inadequate	Deficiency if any
		Tier I	Tier II	Other			
1	60 seats	\$	2.5	3.0	-	-	-
2	100 seats	\$	3.5	5.0	5 Acres	Adequate	-
3	150 seats	\$	5.0	7.0	-	-	-
4	200 seats	\$	6.0	9.0	-	-	-

### B) College campus and general considerations:

Sr. No.	Description	Available / Not Available	Verified by Committee	Deficiency
1	Sale Deed (if applicable)	Not Available		
2	Land Registration details	Available		
3	Lease Deed (if applicable)	Available		
4	Property Tax Paid Receipt of Concern Land	Available		
5	Land Conversion (NA Certificate)	Available		
6	Non Encumbrance Certificate of Concern Land	Available		
7	Zoning Plan	Available		
8	Building Plan (College, Hospital, Hostel)	Available		
9	Building Completion (College, Hospital, Hostel)	Available		
10	Building Occupancy (College, Hospital, Hostel)	Available		
11	Sewage treatment plant	Available		
12	Electricity Backup Plan	Available		
13	Latest 7/12 extract (Enclosure 5)	Available		

(For Point no 9,10 Certifications are subject to regulation as per MES 2024)

### C) Information Technology Cell and Information Technology Infrastructure (MES 24/point 8)

- a) Internet Connection Speed (min req. 500 Mbps) - Available (650 Mbps)
- b) Intranet & Local Area Network Connectivity - Available
- c) Virtual Laboratory - Available
- c) Required Software
- i) Hospital Information Management Software - Available
- ii) Library / OPAC Management System - Available
- iii) Account Management System - Not Available
- iv) College Management System - Not Available
- v) Learning Management System: - Available
- vi) Plagiarism Software (if required) - Available
- d) Digital Library - Available
- e) College Website including all contents (as per point 11) - Available
- f) Aadhaar Enabled Biometric or iris recognition or face rec. attendance - Available

(as per MES 2024 /point 9)

- g) Closed-Circuit Television (CCTV) (MES 24/as per point 10) - Adequate

Signature of Member

Signature of Member

  
**Dr. Yuwaraj D. Kale**  
 M. S. Shalakya (Ayu)  
 Signature of Chairman  
 B.M.A.M. Nagpur.



Estd: 1974

**BACKWARD CLASS YOUTH RELIEF COMMITTEE, NAGPUR**

140, "Rajvilla", Khamla Road, Nagpur - 440025 (M.S.)

Reg. No. Maharashtra - 152/74 (M), F - 1759 (N)

Ph.No. : (0712) 2283543, 2283220 ; Email : bcyrc@bomd.vsnl.net.in

**Smt. Sumanmala B. Mulak**

Chairman

K.D.K. College of Engg.

Chandrapur, Mulak Ayu. Mah. Hospital, Nandanvan, Nagpur

**Shri. Rajendra D. Mulak**

Secretary

**Shri. Yashraj R. Mulak**

Treasurer

Inst. of Diploma in Pharmacy

Umter Shikshan Mahavidyalaya

Ref. No.:

Date:

**IRREVOCABLE RESOLUTION OF THE  
TRUST/SOCIETY**

Resolution passed in the meeting of Backward Class Youth Relief Committee Trust held on 19/08/2019

1. That Nagpur Improvement Trust (NIT) has allotted 16.32 Acres of land to society for the public utility purpose situated at Khasara No.: 321, Mouza- Nagpur, City- Nagpur 440009.
2. That, it is resolved, to earmarked land admeasuring 5.0 Acres out of 16.32 Acres of land situated at Khasara No.: 321, Mouza- Nagpur, Nagpur 440009 for Bhausahab Mulak Ayurved Mahavidyalaya, Nandanvan, Nagpur, which is marked on the map of land, is enclosed hereto.

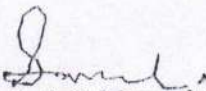
Chairman,   
Backward Class Youth Relief Committee

Backward Class Youth Relief Committee

Secretary **CHAIRMAN** Treasurer

  
Dr. Yuwara D. Kale  
M.S. Shalakra (Ayu)  
Principal  
B.M. Shalakra

BCYRC'S KDK Campus, Great Nag Road,  
Nandanvan, Nagpur

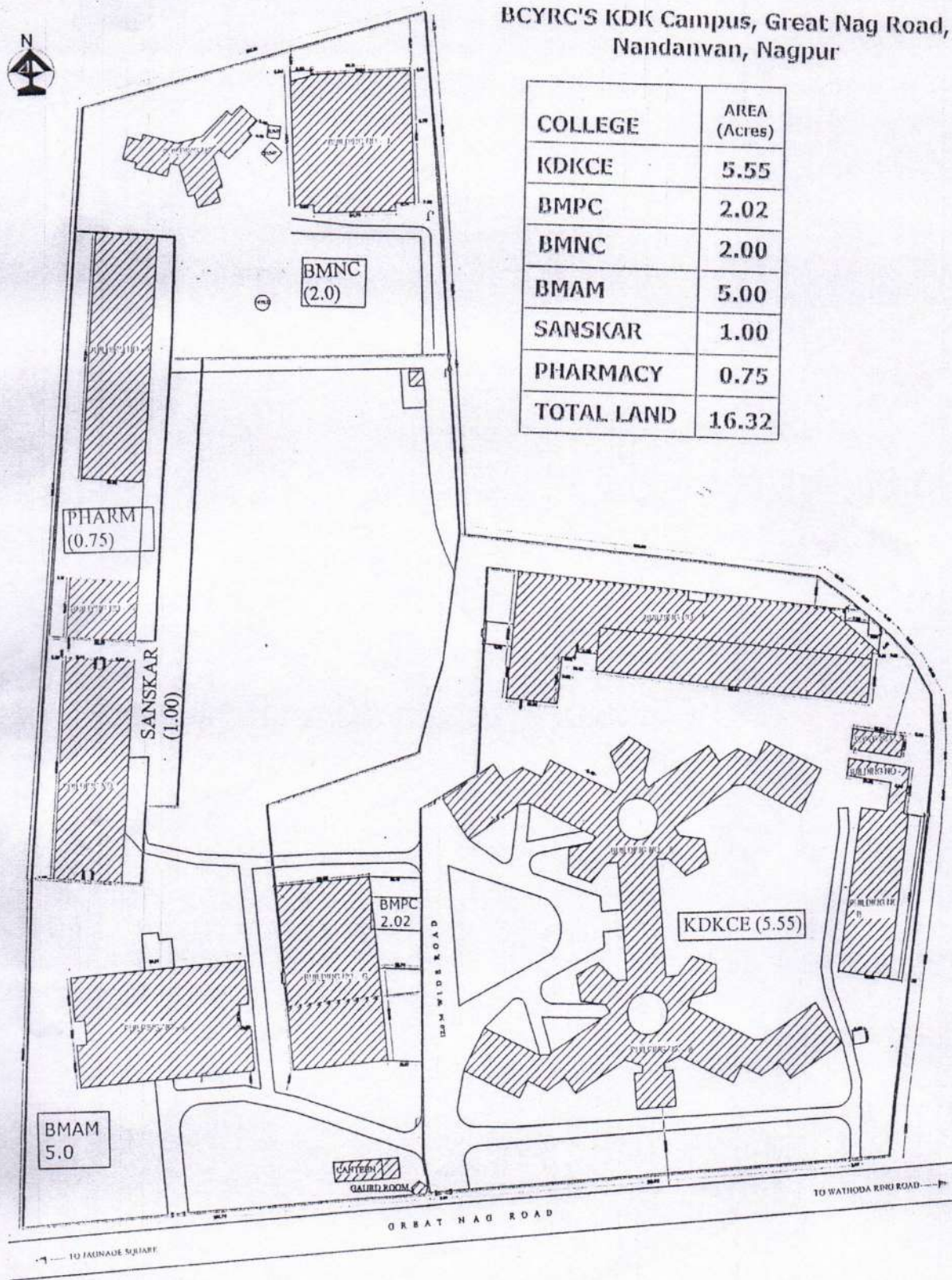

COLLEGE	AREA (Acres)
KDKCE	5.55
BMPC	2.02
BMNC	2.00
BMAM	5.00
SANSKAR	1.00
PHARMACY	0.75
TOTAL LAND	16.32

PRODUCED BY AN AUTODESK EDUCATIONAL PRODUCT

PRODUCED BY AN AUTODESK EDUCATIONAL PRODUCT

Dr. Yuwara D. Kale  
M. S. Shalaky (Ayu)  
Principal  
B.M. ...

BCYRC'S KDK Campus, Great Nag Road,  
Nandanvan, Nagpur

COLLEGE	AREA (Acres)
KDKCE	5.55
BMPC	2.02
BMNC	2.00
BMAM	5.00
SANSKAR	1.00
PHARMACY	0.75
TOTAL LAND	16.32

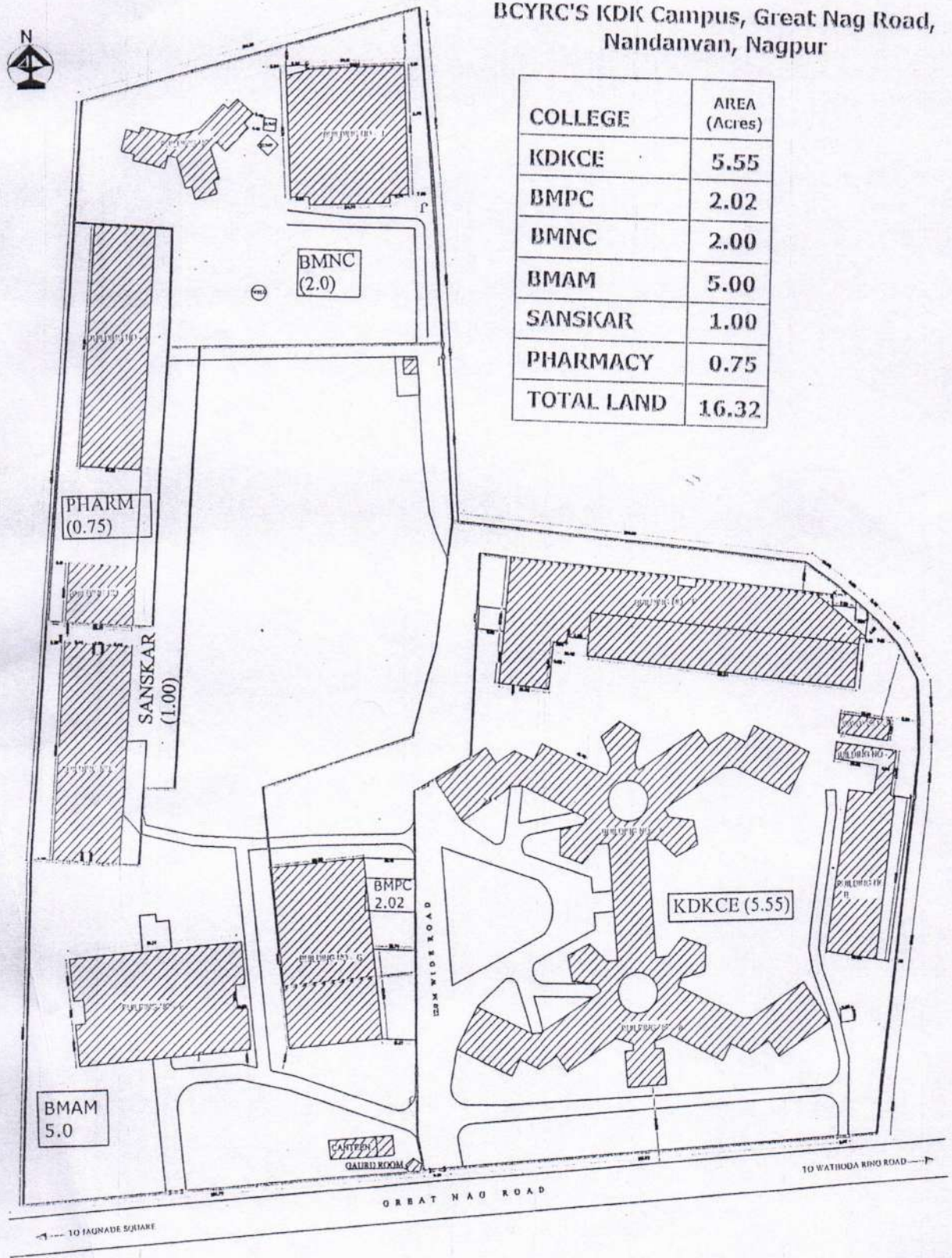

PRODUCED BY AN AUTODESK EDUCATIONAL PRODUCT

PRODUCED BY AN AUTODESK EDUCATIONAL PRODUCT

Dr. Yashraj D. Kale  
M. S. Shalaky (Ayu)  
Principal  
B.M.A.M. Nagpur

B2R B-3



CHALLAN  
MTR Form Number-6

GRN	MH008219511201716E	BARCODE			Date	13/12/2017-14:21:03	Form ID	36
Department	Inspector General Of Registration			Payer Details				
Type of Payment	Stamp Duty Registration Fee	TAX ID (If Any)						
Office Name	NGP1_HQR SUB REGISTRAR NAGPUR 1	PAN No.(# Applicable)	AAATB1267E					
Location	NAGPUR	Full Name	BACKWARD CLASS YOUTH RELIEF COMMITTEE NAGPUR					
Year	2017-2018 One Time	Flat/Block No.	KH NO 321					
Account Head Details		Amount In Rs.	Premises/Building					
0030046401	Stamp Duty	506100.00	Road/Street		MAUZA NAGPUR			
0030063301	Registration Fee	30000.00	Area/Locality		NAGPUR			
			Town/City/District					
			PIN		4 4 0 0 0 1			
			Remarks (If Any)					
			PAN2=AAATB1387E-SecondPartyName=NAGPUR IMPROVEMENT					
			TRUST-CA=1-Marketval=1					
			Amount In		Five Lakh Thirty Six Thousand One Hundred Rupees O			
Total		5,36,100.00	Words		nly			
Payment Details	STATE BANK OF INDIA			FOR USE IN RECEIVING BANK				
Cheque/DD Details		Bank CIN	Ref. No.	00040572017121337080		CKE3884768		
Cheque/DD No.		Bank Date	RBI Date	13/12/2017-14:21:55		Not Verified with RBI		
Name of Bank		Bank-Branch		STATE BANK OF INDIA				
Name of Branch		Scroll No. , Date		Not Verified with Scroll				

NOTE:- This challan is valid for document to be registered in Sub Registrar office only. Not valid for unregistered document. Mobile No. : Not Available  
 सदर चलान केवल दुरत्यज निवधक कार्यालयत नोंदणी करायत्याच्या दस्त्यासाठी लागू आहे. नोंदणी न करायत्याच्या दस्त्यासाठी सदर चलान लागू नाही.

*Shalakye*

नगन-३  
 93TE/209C  
 9 96



Page 1/1  
 D. K. Kulkarni  
 M.S. Shalakye (Ayu)  
 Principal  
 B.K. ...



For PU Plot

# Nagpur Improvement Trust

(Local Planning Authority constituted under Urban Development Department of GOM)  
(www.ninagpur.org)

LAND

Kh. No. 321

Mouza Nagpur

Stamp Duty (Rs.): 506100.00

Regn. Fee (Rs.): 30000.00

## INDENTURE OF LEASE RENEWAL

Premium Rs.: 1224000.00

THIS INDENTURE made this 12<sup>th</sup> day of April 2018 Between the Nagpur Improvement Trust, Acting through its Executive Officer ( hereinafter called the 'LESSOR' which expression shall, unless inconsistent with the context include its successor and assignee) of the ONE PART, and

1) BACKWARD CLASS YOUTH RELIEF COMMITTEE NAGPUR THROUGH ITS AUTHORISED MEMBER SHRI DILIP KRISHNARAO MOHADIK Age: 72 Yrs. Occu: PRIVATE, R/OK.D.K COLLEGE OF ENGINEERING, GREAT NAG ROAD, NANDANVAN NAGPUR-440009

(hereinafter called the "LESSEE" which expression shall unless in consistent with the context include his heirs executors, administrators, representatives and assigness) of OTHER PART :

Whereas by an original indenture dated the 24<sup>th</sup> day of Dec-2007 the lessor demised to the lessee all the plot containing by admeasurement 66078.820 Sq.Meter of hereabouts situated at, Nagpur within the limits of the Nagpur Corporation in Tahsil Nagpur, District Nagpur which said plot of the land is more particularly described in the schedule 'A' hereunder written and with the boundaries thereof for greater clearness delineated on the plan hereto annexed and there on coloured and hatched in Red.

To hold the same for and commencing from the 09<sup>th</sup> day of MAY-1986 and ending on 08<sup>th</sup> day of MAY-2016 the said indenture containing a covenant for the renewal of demise on the expiry of the aforesaid term and it being expired.

नगन-३  
9358/2090  
३/१६



Dr. Yuwaraj K. Kale  
Ms. S. Shalakra (Ayu)  
B.H. ...

(2)

AND WHEREAS in pursuance of the said agreement the "Lessee" **BACKWARD CLASS YOUTH RELIEF COMMITTEE NAGPUR THROUGH ITS AUTHORISED MEMBAR SHRI DILIP KRISHNARAO MOHADIK** has now requested the "Lessor" to execute a new lease to him/her in accordance with the said convent, know all men by these presents that the "Lessor" here by demises to the "Lessee" all the aforesaid plot of land.

To hold the same in continuation of the original lease-deed for the second term commencing from the 09th day of MAY-2016 and ending on 08th day of MAY-2046 subject to the following conditions:-

TERMS AND CONDITIONS

- (a) That, the "Lessee" shall pay the yearly ground rent of Rs. 73440.00 (Rupees in Word Seventy Three Thousand Four Hundred Forty Rupees Only) on the undivided leasehold share of land and clear of all deduction on or before the first day of June in each year at the office of Nagpur Improvement Trust, Nagpur the "Lessor", during subsistence/continuance of the lease may revise the ground rent as per policy framed by the Board of Nagpur Improvement Trust, Nagpur as well as Government and shall be binding on "Lessee" and the "Lessee" has to pay such enhanced ground rent to the "Lessor" without any default or demur.
- (b) The first of such payment is to be made on the first day of June 2017. The "Lessee" at present Pays Rs. 427571.00 as prevailing Corporation Taxes per annum. Total annual average rent is Rs. 501011.00 per annum.
- (c) The "Lessee" shall pay corporation taxes as assessed by the Nagpur Municipal Corporation from time to time, N.A. assessment and any other taxes, levies charges whatsoever.
- (d) The "Lessee" shall not make any excavation upon any part of the said land or remove any stone, sand, gravel, bay or earth there from except for the purpose of forming the foundation or building or for the purpose of executing any work pursuant to the terms of this LEASE and in doing so the LESSEE shall exercises reasonable care to ensure that foundations of any building on the adjoining plots are not hereby adversely affected.
- (e) No erection re-erection or alteration shall be made in any building or part thereof on the said land except in accordance with the sanction of the Nagpur Improvement Trust under its Building Regulations and Development Control Rules, nor shall a building be put to any use in contravention of the provisions of any regulation made under clause (h) of section 90 of the Nagpur Improvement Trust Act, 1936.
- (f) That, after the expiry of the initial period of 30 years, at the time of every renewal of lease, the LESSEE/ASSIGNEE shall be liable to pay three (3) times minimum of existing ground rent after the expiration of every 30 years lease period in respect of demised plot at the time of renewal. The rate of the ground rent due shall be fixed as per the decision of the Trust/LESSOR.

747-3  
9352/2096  
8/96



(3)

(g) The LESSEE/ASSIGNEE shall take the building permission from Appropriate Planning Authority, for the construction of building before starting constructions on the demised land. The construction of the building should be as per the sanctioned plan approved by the Planning Authority. If any permission for multistoried building was granted, in that case, the Deed of Declaration should be in accordance with the sec. 4, 10, 11, 12 of the Maharashtra Apartment Ownership Act, 1970 and got registered.

(h) If the demised land is subjected for the development wherein the LESSEE executes the development agreement with the DEVELOPER/BUILDER under this circumstances after the completion of entire project the re-conveyance deed shall be executed by the DEVELOPER/BUILDER in favour of the LESSEE/ASSIGNEE/SOCIETY/ASSOCIATION as per the provisions of Registration Act and other relevant laws.

Provided any documents related with the lease plot should be registered before the Registrar under the relevant provisions of Registration Act, 1908 shall be treated as a valid document of evidence of title of LESSEE/ASSIGNEE.

(i) The LESSEE shall permit the LESSOR, or any servant of the Nagpur Improvement Trust at all reasonable time of the day during the terms hereby granted to enter into and upon the demised premises and to inspect the site for repairs thereof and if upon such inspection it shall appear that any repairs are necessary the LESSOR may direct the LESSEE to execute the repairs and upon his failure to do so within a reasonable time to execute them at the expense in all respects of the LESSEE.

(j) The LESSEE shall permit the LESSOR or any person nominated by it or any servant or contractor of the Nagpur Improvement Trust, the Nagpur Corporation and Maharashtra State Electrical Board to enter into and upon the demised premises with such workmen, as may be necessary for the purpose of laying repairing or replacing a water pipe line, sewer line or an electric supply line or for any work connected therewith, as also for the purpose of making any connection from the house to those service lines laid in the premises.

(k) The LESSEE shall not disturb or build over or otherwise deal with so as to impair utility without previous permission of the LESSOR on survey marks or sub traverse make existing on the land which are for clearness shown 'Nil' on the plan hereto annexed and which are specified in Schedule 'B' hereunder written.

(l) The LESSEE shall not disturb or build over or otherwise deal with or interfere with any of the service lines, referred to in sub-clause (c) without the previous permission in writing of the authority which laid the service line.

(m) The LESSEE shall not assign transfer or part with the possession of the demised premises so as to cause any sub-division therein or otherwise to alter nature of this present demise.

Provided however, that the LESSOR may subject to such terms and conditions, as it may fix grant permission to the LESSEE to part with permission of the demised premises so as to cause any subdivision therein, otherwise alter the nature of this present demise.

नगन-३	
१३५६/२०१८	
५	१६



Dr. Yumara D. Kale  
M. S. Shalakra (Ayu)  
Principal  
B. J. ...

Provided further that, where sub-division of the demised plot is permissible as per the rules and LESSEE with an intention to sub-divide the demised plot and applies for sub-division and the permission to transfer/assign the sub-divide the demised plot and when such permission is granted the LESSEE shall have to pay 50% of the unearned income if the transfer/assignment is/was made within five years from the date of sub-division of plot, the unearned income shall be payable as per difference between premium paid and the market price of the land prevailing on the date of sale. In case there is dispute regarding market price of sub-divided plot, the decision of the Chairman shall be conclusive and final and binding to the LESSEE

(n) The LESSEE shall not without the previous permission in writing of the LESSOR, use or allow to be used the premises of the demised land in contravention of the regulation framed u/sec. 90 of the Nagpur Improvement Trust Act, 1936 and Development Control Rules.

(o) The LESSEE as also the assignee and the mortgagor/mortgage shall within one month of assignment, mortgage or transfer of the demised premises deliver a notice of such of assignment, mortgage or transfer to the LESSOR setting for the names and description of the parties to every such assignment, mortgage or transfer and particular and the effect thereof.

(o-1) The LESSOR, in case the notice referred to in sub-clause (o) is delivered to it, shall intimate to the LESSEE, assignee, and mortgagee or transferee about arrears of the trust due and its right of re-entry repossession over the demised premises to remedy breach of any or all clauses of condition of lease within a period of the three month of the date of the intimation of that effect.

(p) The LESSEE shall use demised land/plot as per allotment order. If, the LESSEE/ASSIGNEE use the demised land other than that of order as per allotment it is to be treated as breach of condition of the Lease Deed under this circumstances the LESSEE/ASSIGNEE shall be liable for action for cancellation of lease or penalty as per the prevailing Law/Rules & regulation.

(q) This INDENTURE of LEASE the conditions and terms contained therein would be subject to Nagpur Improvement Trust Land Disposal Rules 1983, which has overriding effect and further that if the plot is allotted on concessional rates additional conditions mentioned in Rules 24,16 & 20 including any amendments therein from time to time would be applicable.

(q-1) The plot is allotted on the concessional premium and hence condition as described under Rules 24,16 & 20 including any amendments therein from time to time of the Nagpur Improvement Trust Land Disposal Rules, 1983 and as may be imposed by the Chairman shall be applicable.

(r) The decision of the LESSOR or any person it may appoint in this behalf on any question, which may arise, concerning any alleged breach of any of the foregoing clauses shall be final.

(s) The LEASE of demised land shall be suspended or cancelled, if the LESSEE/ASSIGNEE files any false information/documents regarding title acquired by him/her.

प्लॉट - 3	
935E/2096	
E	96



(t) The LESSOR covenants that the LESSEE paying the rent thereby reserved and performing and observing the conditions herein contained shall peaceably hold and enjoy the said land during the said term without any lawful interruption or disturbance by the LESSOR or any person lawfully claiming through it.

Provided that if the said rent or any part thereof shall at any time be in arrears and unpaid for one Calendar month next after the date where on the same shall have become due whether they shall have been lawfully demanded or not, as also upon the breach or non-observance by the LESSEE of any of the said conditions, the LESSOR may notwithstanding the waiver of any previous causes or right of re-entry upon the said land and reposes it as if this demise had been made the LESSEE in such case being entitled within three Calendar months from the date of such re-entry.

Provided further that when any cause or right of re-entry arise under the foregoing provision, it shall be lawful for the LESSOR, as the consideration for the non-exercise of the power of re-entry to receive from the LESSEE a sum of money not exceeding Two years ground rent plus interest @ 12% p.a. or as may be decided from time to time shall levied in case of payment of ground rent made after due date i.e. 1st of June of each year.

Provided also that when any cause or right off re-entry arises under the first provision, upon the breach or non-observance of the conditions of clause and sub clauses, thereof in respect of erection or alternation, it shall be lawful for the LESSOR to ask the LESSEE to demolish or alter the unauthorized construction, as it may deem necessary, within reasonable time, as a consideration for the non-exercise of the power of re-entry instead of receiving a sum of money as provided above.

(u) That, in case of any dispute between the LESSOR AND LESSEE regarding the breach of any term or condition of the Lease Indenture, the decision of the Chairman of LESSOR shall be final and binding on the parties.

(v) The LESSEE/ LESSESS, has/have read and understood the provisions of the Land Disposal Rules and agrees to abide by the provisions of Land Disposal Rules 1983, terms and conditions of this lease and the Resolutions passed/Policies framed by the LESSOR from time to time.

The LESSOR further covenants that, after the expiry of lease period, lease may be renewed as per the prevailing Rules & Regulations and policies framed by Nagpur Improvement Trust, Nagpur at the time of subsequent lease renewal.

This lease deed is being executed subject to decision of PIL 2227/2004 Shri Wadpalliwar -vs- NIT., Maharashtra State and others.

ना.न-३
१३८६/२०१८
६/१६



Dr. Yuvraj D. Kale  
M.S. Shalakra (Ayu)  
B.N. ...

(6)

'SCHEDULE "A"

LAND IN WATHODA STREET SCHEME

N.I.T. Kh.No. 321 Mouza Nagpur layout/ Precinct

Nagpur / Ward No. 20 Division SOUTH Tahsil, and District Nagpur.

Admeasuring 66078.820 Sq.Meter 711272.00 Sq.ft Dimensions are marked on plan enclosed.

Sheet No. 249

City Survey No. 101

USER OF PLOT : PUBLIC UTILITY

( As Per Allotment )

Boundaries:- NORTH - NAG.RIVER & LAND  
SOUTH - ROAD  
EAST - LAND  
WEST - NANDANWAN SLUM

'SCHEDULE "B"

NIL

In witness where of the parties here to have set their hands the day and year written in each case.

Witness :-

Executive Officer

Nagpur Improvement Trust

LESSOR

Date 12/4/2018



1st Witness :-



2nd Witness :-



LESSEE

Date 12/4/2018

नगन-3  
9358/2096  
5/96

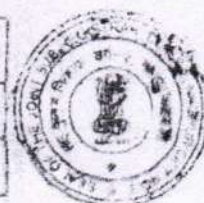

NANDANWAN SLUM

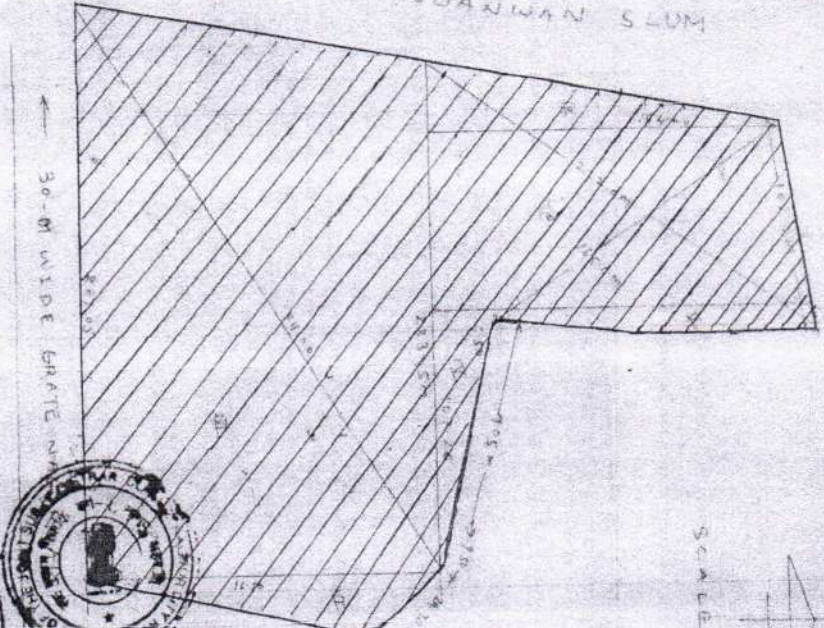

गगन-3  
93CE 2096  
e 96



Assistant Director Town Planning  
Municipal Improvement Trust

*(Signature)*

*(Signature)*  
Asst. Engineer (Planning)  
Municipal Improvement Trust

IS.U.V.T

*(Signature)*  
EXECUTIVE OFFICER  
MUNICIPAL IMPROVEMENT TRUST

*(Signature)*  
LEASER

Plot Area - 66078.82 SQ.MT  
DEDUCTION CURIATURE - 50 SQ.MT  
TOTAL PLOT AREA - 66078.82 SQ.MT  
LAND LEASED OUT TO  
SMT PRESIDENT, BACKWARD CLASS YOUTH RELIEF COMMITTEE  
MARRPUR

A - B	97.4
C - D	---
D - A	---

AS PER C-176

SKETCH SHOWING  
PLOT NO. - 321  
LAND OF PLOT NO. 321  
NAME OF STREET: WATKAR STR. SEC. 1  
SARITHEKOTIPURATHA 1555/17/5/10  
MARRPUR DISTRICT, 612/1957  
PUBLIC-56/MARRPUR  
COLLAGE

*(Signature)*  
Kala  
Shakya (Ayu)

**भारत सरकार**  
**Government of India**

**दिलीप कृष्णराव महाडिक**  
**Dilip Krushnrao Mahadik**  
**जन्म तारीख / DOB : 28/05/1945**  
**पुरुष / Male**



**9603 9239 4212**

**आधार - सामान्य माणसाचा अधिकार**

**भारतीय पहचान आयोग प्राधिकरण**  
**Unique Identification Authority of India**

**पत्ता प्लॉट नं 342/733 सी, पी.टी. मास्से मार्ग, दीक्षाभूमी समोर, लक्ष्मी नगर, राणाप्रताप नगर, राणाप्रताप नगर, नागपूर, महाराष्ट्र, 440022**

**Address: plot no 342/733 C, P.T. masse marg, opposite dikshathumi, laxmi nagar, Ranapratap Nagar, Ranapratap Nagar, Nagpur, Maharashtra, 440022**

**9603 9239 4212**





*Mahadik*

**नगन-३**  
**93CE / 2096**  
**99 / 96**



**स्थायी लेखा संख्या / PERMANENT ACCOUNT NUMBER**  
**AAATB1267E**

**नाम / NAME**  
**BACKWARD CLASS YOUTH RELIEF COMMITTEE**

**निगमन/बनने की तिथि / DATE OF INCORPORATION/FORMATION**  
**24-09-1974**

  
**COMMISSIONER OF INCOME TAX, VIGARGAH**

05

**Dr. Yuwara J. D. Kale**  
**M. S. Shalaky (Ayu)**  
**Principa**  
**B.M.A.M. Hospital**



भारतीय विशिष्ट ओळख प्राधिकरण  
 भारत सरकार  
 Unique Identification Authority of India  
 Government of India

नोंदविण्याचा क्रमांक / Enrollment No.: 1207/13526/01418

To  
 रमेश चिन्हेराव मुळक  
 Ramesh Chindherao Mulak  
 near kdk boy hostel flat no. m101 maa durga society  
 nandanavan  
 Hanuman Nagar S.O  
 Hanuman Nagar  
 Nagpur  
 Maharashtra 440009  
 8087339313  
 382572177  
 MA825721779FT



आपला आधार क्रमांक / Your Aadhaar No. :

4612 8180 2119

माझे आधार, माझी ओळख



भारत सरकार  
 Government of India  
 रमेश चिन्हेराव मुळक  
 Ramesh Chindherao Mulak  
 जन्म तारीख / DOB: 15/03/1946  
 पुरुष / Male



4612 8180 2119

माझे आधार, माझी ओळख

*Handwritten signature*



भारतीय विशिष्ट पहचान प्राधिकरण  
 UNIQUE IDENTIFICATION AUTHORITY OF INDIA

पत्ता:  
 S/O रमेश साठोने, प्लॉट नं.  
 Y-ए, अरुणोदय, तिरुपती  
 वेंक मागे, विजयानंद  
 सोसायटी, नरेंद्र नगर,  
 नागपुर, नागपुर,  
 महाराष्ट्र - 440015

Address:  
 S/O Ramesh Satone Plot No. 4A,  
 Arunodaya Behind Tirupati Bank  
 Vijayanand Society, Narendra Nagar  
 Nagpur, Nagpur,  
 Maharashtra - 440015

6408 4106 3081

Aadhaar-Aam Admi ka Adhikar



भारत सरकार  
 GOVERNMENT OF INDIA



स्वप्नील रमेश साठोने  
 Swapneel Ramesh Satone  
 जन्म तारीख / DOB: 11/02/1980  
 पुरुष / MALE



6408 4106 3081

आधार-सामान्य माणसाचा अधिकार

*Handwritten signature*

लगन-3  
 93८६/२०१८  
 92/१७



1414266  
13/04/2018

## नोंदणीपुर्व गोपवारा

दुय्यम निबंधक : सह. दु. नि. नगत 3

एन्ट्री क्रमांक : 1414/2018

(1) विलेखाचा प्रकार	भाडेपट्टा	1) ही माहिती पत्रकारांनी सशक्तित केलेल्या इनपुट फॉर्मवर आधारित आहे.
(2) मोबदला	रु. 0	2) दस्ताची माहिती संगणकावर घेण्यात आली. याचा अर्थ दस्त नोंदणीसाठी स्वीकारला असा नाही. दुय्यम निबंधक दस्त नाकारू शकतात किंवा नियमांनुसार योग्य ती अन्य कार्यवाही करू शकतात.
(3) बाजारभाव	रु. 10122000	3) बदल /दुरुस्त्या कराव्यात. लागू नसलेला मजकूर सोडावा.
(4) आवश्यक मुद्रांक शुल्क	रु. 455490	
(5) दस्त निष्पादित केल्याचा दिनांक	12/04/2018	
(6) गावाचे नाव	नागपूर (खाम)-- नागपूर म. न. पा.	
(7) पृष्ठांची संख्या	16	
(8) भू-मापन, पोटहिस्सा व घरक्रमांक (असल्यास)	1) C.T.S. Number : 101 ;	
(9) मालमत्तेचे इतर वर्णन	1), इतर माहिती: मौजा नागपूर वार्ड नंबर 20 खसरा नंबर 321 जागा एकुण क्षेत्र 66078.820 चौ.मी. शिट नंबर 249 सिटीएस नंबर 101. 1), Other Details: Mauja Nagapur Vard Nambar 20 Khasara Nambar 321 Jaga Ekun Kshetr 66078.820 Chau.mi. Shit Nambar 249 Sities Nambar 101.	
(10) क्षेत्रफळ	1) 66078.82 चौ.मीटर	
(11) दस्तऐवज करून देणाऱ्या /लिहून देणाऱ्या पत्रकाराचे नाव व पत्ता	1) बँकवई क्लाम युथ रिलिफ कमिटी नागपूर तर्फे अधिकृत मेंबर दिलीप कृष्णराव महाडीक . वय:-72 पत्ता:-, , , , , केडीके कॉलेज आफ इंजिनिरिंग ग्रेट नाग रोड नंदनवन नागपूर 9890020856, डी.गु. ऑरी नाका , MAHARASHTRA, NAGPUR, Non-Government. पिन कोड:-440009 पॅन नं:-AAATB1267E 1) backward class youth rilif committee nagpur tarfe adhikrut membar dilip krushnarao mahadik . . Age:-72 Address:-, , , , , Kedike Kolej Aph Injining Gret Nag Rod Nandanavan Nagapur 9890020856 , DIGHORI NAKA, MAHARASHTRA, NAGPUR, Non-Government. Pin Code:-440009 Pan No.:-AAATB1267E	
(12) दस्तऐवज करून घेणाऱ्या /लिहून घेणाऱ्या पत्रकाराचे नाव व पत्ता	1) नागपूर सुधार प्रन्यास, नागपूर कार्यकारी अधिकारी, श्री प्रशांत मनोहरराव भांडारकर यांचे तर्फे कबुलीजबाब देशार श्री राजेश मधुकर समरीत . वय:-53; पत्ता:-प्लॉट नं: .. माळा नं: .. इमारतीचे नाव: .. ब्लॉक नं: .. रोड नं: नागपूर सुधार प्रन्यास, कार्यालय, सदर नागपूर, महाराष्ट्र, नागपूर. पिन कोड:-440001 पॅन नं:- 1) nagpur sudhar pranyas, nagpur karyakari adhikari, shri prashant manoharao bhandarkar yanche tarfe kabulijabab denar shri rajesh madhukar samrit . . Age:-53 Address:-Flat No.: ., Floor No.: ., Building: ., Block Sector: ., Road: nagpur sudhar pranyas, karyalay, sadar nagpur, State: MAHARASHTRA, District: NAGPUR. Pin Code:-440001 Pan No.:-	
(13) ओळख देणाऱ्यांचे तपशील	1) स्वप्नील रमेश साटोने . वय:-38 पत्ता:-विजयानंद सोसायटी नरेंद्र नगर नागपूर पिन कोड:-440009 1) swapnil ramesh satone . . Age:-38 Address:-vijayanand society narendra nagar nagpur PIN Code:-440009 2) रमेश चिन्धेराव मुळक . वय:-72 पत्ता:-मा दुर्गा सोसायटी, नंदनवन नागपूर पिन कोड:-440009 2) ramesh chindherao mulak . . Age:-72 Address:-maa durga society, nandanvan nagpur PIN Code:-440009	

नागपूर-३  
93८६/२०१८  
93/१६



नोंदणीपुर्व गोपवारा मध्ये इनपुट फॉर्म प्रमाणे अचूक डाटा एन्ट्री करण्यात आली आहे.

नोंदणीपुर्व गोपवारा तपासून पाहिला. तो बरोबर आहे/त्याच्यात नमुद केलेल्या दुरुस्त्या कराव्यात.

( डाटा एन्ट्री ऑपरेटर स्वाक्षरी )

( पत्रकाराची स्वाक्षरी )

नोंदणीपुर्व गोपवारा इनपुट फॉर्म प्रमाणे आहे व याचा मेळ मुळ दस्ताशी घेण्यात आला आहे. पत्रकाराने नमुद केलेले बदल/दुरुस्त्या याचा समावेश करण्यात आला आहे.

( NGP3 स्वाक्षरी )

Dr. Yuwaraj D. Kal  
M. S. Shalakyar (Ayu)  
Principal  
B.M.A.V. Hospital

मूल्यांकनासाठी विचारान घेतलेला तपशील: ..... दस्तप्रकारनुसार आवश्यक नाही ..... दस्तप्रकारनुसार  
आवश्यक नाही)

मुद्रांक शुल्क आकारताना निवडलेला अनुच्छेद: (i) within the limits of any Municipal Corporation or any Cantonment area annexed to it. ( 84 )

दस्त भारतात आल्याचा दिनांक: -----

Note ExemptionUnder88:-(₹) . sign of party:-(£) . दस्त नोंदणीनंतर आपणान मूळ दस्त व थंबनेल प्रिंट मिळेल.

#### Seller Details

SR. NO.	Khata No.	Property No.	Party Name	Navi Area	Vikri Area	Navi Potkharab	Vikri Potkharab
1	0	-	नागपूर सुधार प्रत्यास, नागपूर कार्यकारी अधिकारी, श्री प्रशांत मनोहरराव भांडारकर यांचे तर्फे कबुलीजवाब देणार श्री राजेश मधुकर समरीत . .	0.0	0.0	0.0	0.0

#### Buyer Details

SR. NO.	Khata No.	Property No.	Party Name	Kharidi Area	Kharidi Potkharab	Seller Khata No.	Seller Name
1	0	-	वैकवई क्लाम युथ रिविफ कमिटी नागपूर तर्फे अधिकृत मेबर दिलीप कृष्णराव महाडीक . .	0.0	0.0	0	

नागपूर-३  
९३८६/२०९८  
९४/९६





**CHALLAN**  
MTR Form Number-6

GRN	MH008219511201718E	BARCODE			Date	13/12/2017-14:21:03	Form ID	36	
Department	Inspector General Of Registration			Payer Details					
Type of Payment	Stamp Duty Registration Fee	TAX ID (If Any)							
Office Name	NGP1_HQR SUB REGISTRAR NAGPUR 1	PAN No.(If Applicable)	AAATB1267E						
Location	NAGPUR	Full Name	BACKWARD CLASS YOUTH RELIEF COMMITTEE NAGPUR						
Year	2017-2018 One Time	Flat/Block No.	KH NO 321						
Account Head Details		Amount In Rs.	Premises/Building	MAUZA NAGPUR					
0030046401	Stamp Duty	506100.00	Road/Street						
0030063301	Registration Fee	30000.00	Area/Locality	NAGPUR					
			Town/City/District						
			PIN	4	4	0	0	0	1
			Remarks (If Any)	PAN2=AAATB1367E--SecondPartyName=NAGPUR IMPROVEMENT TRUST-CA=1--Marketval=1					
Total		5,36,100.00	Amount in Words	Five Lakh Thirty Six Thousand One Hundred Rupees 0					
Payment Details	STATE BANK OF INDIA			FOR USE IN RECEIVING BANK					
Cheque/DD Details			Bank CIN	Ref. No.	00040572017121337080	CKE3884768			
Cheque/DD No.			Bank Date	RBI Date	13/12/2017-02:21:50	14/12/2017			
Name of Bank				Bank-Branch	STATE BANK OF INDIA				
Name of Branch				Scroll No. , Date	348 , 14/12/2017				



NOTE:- This challan is valid only if it is registered in Sub Registrar office only. Not valid for unregistered document. Mobile No. : Not Available  
सदर चलन केवल दस्त नोंदणी करवायाच्या दस्तासठी लागू आहे. नोंदणी न करवायाच्या दस्तासठी सदर चलन लागू नाही.

Digitally signed by D3 VIRTUAL TREASURER MUMBAI 01 Date: 2018.04.13 10:12:41 IST Reason: Secure Document Location: India

Sr. No.	Remarks	Defacement No.	Defacement Date	Userld	Defacement Amount
1	(IS)-266-1386	0000287912201819	13/04/2018-10:12:40	IGR385	30000.00

नगण-३  
93८६/२०१८  
१५/१६



Print Date 13-04-2018 10:12:41  
Dr. Yuwaraj D. Kale  
M.S. Shalakyar (Ayu)  
Principal  
B.I.

266/1386  
शुक्रवार, 13 एप्रिल 2018 10:13 म.पू.

दस्त गोपवारा भाग-1

नगन3 9E-96  
दस्त क्रमांक: 1386/2018

दस्त क्रमांक: नगन3 /1386/2018

बाजार मूल्य: रु. 1,01,22,000/-

मोबदला: रु. 00/-

भरलेले मुद्रांक शुल्क: रु. 5,06,100/-

दु. नि. सह. दु. नि. नगन3 यांचे कार्यालयात

अ. क्र. 1386 वर दि. 13-04-2018

रोजी 10:01 म.पू. वा. हजर केला.

पावती: 1899

पावती दिनांक: 13/04/2018

सादरकरणाराचे नाव: बँकवई क्ल्याम युथ रिलिफ कमिटी नागपूर तर्फे  
अधिकृत मॅबर दिलीप कृष्णराव महाडीक . .

नोंदणी फी

रु. 30000.00

दस्त हाताळणी फी

रु. 340.00

पृष्ठांची संख्या: 17

दस्त हजर करणाऱ्याची मही:

एकुण: 30340.00

सहस्रमुख्यम निबंधक, वर्ग-२

नागपूर शहर क्र. ३.

दस्ताचा प्रकार: भाडेपट्टा

मुद्रांक शुल्क: (एक) कोणत्याही महानगरपालिकेच्या हद्दीत किंवा स्थालगत असलेल्या कोणत्याही कटक क्षेत्राच्या हद्दीत किंवा उप-खंड (दोन)  
मध्ये नमूद न केलेल्या कोणत्याही नागरी क्षेत्रात

शिक्रा क्र. 1 13 / 04 / 2018 10 : 01 : 02 AM ची वेळ: (सादरीकरण)

शिक्रा क्र. 2 13 / 04 / 2018 10 : 03 : 00 AM ची वेळ: (फी)

सहस्रमुख्यम निबंधक, वर्ग-२  
नागपूर शहर क्र. ३.





13/04/2018 10 15:06 AM







दस्त गोषवारा भाग-2

नगन3 १६-१७

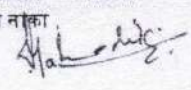
दस्त क्रमांक:1386/2018

दस्त क्रमांक :नगन3/1386/2018

दस्ताचा प्रकार :-भाडेपट्टा





अनु क्र.	पक्षकाराचे नाव व पत्ता	पक्षकाराचा प्रकार	छायाचित्र	अंगठ्याचा ठसा
1	नाव:बॅकवर्ड क्लास युथ रिलिफ कमिटी नागपूर तर्फे अधिकृत मेंबर दिलीप कृष्णराव महाडीक .. पत्ता:.., .., .., केडीके कॉलेज ऑफ इंजिनिरिंग ग्रेट नाग रोड नंदनवन नागपूर 9890020856, डीग:ओरी नाका MAHARASHTRA, NAGPUR, Non- Government. पॅन नंबर:AAATB1267E	भाडेकरू वय :-72 स्वाक्षरी:- 		
2	नाव:नागपूर सुधार प्रन्वाम, नागपूर कार्यकारी अधिकारी, श्री प्रशांत मनोहरराव भांडारकर यांचे तर्फे कदलीजबाब देणार श्री राजेश मधुकर समरीत .. पत्ता:प्लॉट नं: .. माळा नं: .. इमारतीचे नाव: .., क्लॉक नं: .. रोड नं: नागपूर सुधार प्रन्वाम, कार्यालय, सदर नागपूर, महाराष्ट्र, नागपूर. पॅन नंबर:	मालक वय :-53 स्वाक्षरी:- 		

बरील दस्तऐवज करून देणार तथाकथित भाडेपट्टा चा दस्त ऐवज करून दिल्याचे कबूल करतात.  
शिक्का क्र.3 ची वेळ:13 / 04 / 2018 10 : 04 : 00 AM

सह दुय्यम निबंधक, वर्ग-२  
नागपूर शहर क्र. ३.

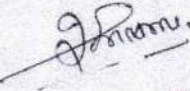
ओळख:-

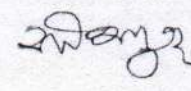
खालील इमम असे निवेदीत करतात की ते दस्तऐवज करून देणा-यानां व्यक्तीशः ओळखतात, व त्यांची ओळख पटवितात

अनु क्र.	पक्षकाराचे नाव व पत्ता	पक्षकाराचा प्रकार	छायाचित्र	अंगठ्याचा ठसा
1	नाव:स्वप्नील रमेश साटोने .. वय:38 पत्ता:विजयानंद सोसायटी नरेंद्र नगर नागपूर पिन कोड:440009	स्वाक्षरी 		
2	नाव:रमेश चिन्हेराव मुळक .. वय:72 पत्ता:भा दुर्गा सोसायटी,नंदनवन नागपूर पिन कोड:440009	स्वाक्षरी 		

शिक्का क्र.4 ची वेळ:13 / 04 / 2018 10 : 04 : 43 AM

शिक्का क्र.5 ची वेळ:13 / 04 / 2018 10 : 04 : 57 AM नोंदणी पुस्तक 1 मध्ये

प्रमाणित करण्यात येई कि, या दस्ताऐवजात  
एकूण १७ पाने आहेत.

सह दुय्यम निबंधक, वर्ग-२

नागपूर शहर क्र. ३ Payment Details.

१ नंबराचे बुकाचे  
११८६ नंबरी नोंदला

सह दुय्यम निबंधक वर्ग-२,  
नागपूर शहर क्र. ३,  
दि.१३. माहे.०४. सन २०१८

sr. Epayment Number Disbursement Number  
1 MH008219511201718E 000287912201819



1. Verify Scanned Document for correctness through In-house (14 pages on a side) printout after scanning  
2. Get print immediately after registration

For feedback, please write to us at feedback.isarita@gmail.com

1386 / 2018

Dr. Yuvaraj D. Kale  
M. S. Shalakyas (Ayu)  
Principal



**CHALLAN**  
MTR Form Number-6

GRN	MH008219511201718E	BARCODE	Date		13/12/2017-14:21:03	Form ID	36
Department				Inspector General Of Registration			
Type of Payment				Stamp Duty Registration Fee			
Office Name				NGP1_HQR SUB REGISTRAR NAGPUR 1			
Location				NAGPUR			
Year				2017-2018 One Time			
Account Head Details				Amount In Rs.			
0030046401 Stamp Duty				506100.00			
0030063301 Registration Fee				30000.00			
Total				5,36,100.00			
Payment Details				STATE BANK OF INDIA			
Cheque/DD No.				Bank CIN			
Name of Bank				Ref. No.			
Name of Branch				Bank Date			
				RBI Date			
				Bank-Branch			
				Scroll No. , Date			
				FOR USE IN RECEIVING BANK			
				00040572017121337080			
				CKE3884768			
				13/12/2017-14:21:55			
				Not Verified with RBI			
				STATE BANK OF INDIA			
				Not Verified with Scroll			

NOTE:- This challan is valid for document to be registered in Sub Registrar office only. Not valid for unregistered document. Mobile No. : Not Available  
सदर चलन केवल दुर्यम निबंधक कार्यालयत नोदणी करवायाच्या दस्तांसाठी लागू आहे. नोदणी न करावयाच्या दस्तांसाठी सदर चलन लागू नाही.

**नगन-३**  
93CE/209C  
9/96



*M. S. Shalaky*

Dr. Yuwaraj B. K. K. K.  
M. S. Shalaky (Ayu)  
Principal  
B.K. ...



For PU Plot

# Nagpur Improvement Trust

(Local Planning Authority constituted under Urban Development Department of GOM)  
(www.nitnagpur.org)

LAND ✓

Kh. No. 321 ✓

Mouza Nagpur ✓

Stamp Duty (Rs.): 506100.00 ✓

Regn. Fee (Rs.): 30000.00 ✓

## INDENTURE OF LEASE RENEWAL

Premium Rs.: 1224000.00 ✓

THIS INDENTURE made this 12<sup>th</sup> day of April 2018 Between the Nagpur Improvement Trust, Acting through its Executive Officer ( hereinafter called the 'LESSOR' which expression shall, unless inconsistent with the context include its successor and assignee) of the **ONE PART**, and

1) **BACKWARD CLASS YOUTH RELIEF COMMITTEE NAGPUR THROUGH ITS AUTHORISED MEMBAR SHRI DILIP KRISHNARAO MOHADIK** Age: 72 Yrs. Occu: PRIVATE, R/OK.D.K COLLEGE OF ENGINEERING, GREAT NAG ROAD, NANDANVAN NAGPUR-440009

(hereinafter called the "LESSEE" which expression shall unless in consistent with the context include his heirs executors, administrators, representatives and assigness) of **OTHER PART** :

Whereas by an original indenture dated the 24<sup>th</sup> day of Dec-2007 the lessor demised to the lessee all the plot containing by admeasurement 66078.820 Sq.Meter of hereabouts situated at, Nagpur within the limits of the Nagpur Corporation in Tahsil Nagpur, District Nagpur which said plot of the land is more particularly described in the schedule 'A' hereunder written and with the boundaries thereof for greater clearness delineated on the plan hereto annexed and there on coloured and hatched in Red.

To hold the same for and commencing from the 09<sup>th</sup> day of MAY-1986 and ending on 08<sup>th</sup> day of MAY-2016 the said indenture containing a covenant for the renewal of demise on the expiry of the aforesaid term and it being expired.

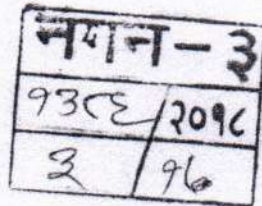

AND WHEREAS in pursuance of the said agreement the "Lessee" BACKWARD CLASS YOUTH RELIEF COMMITTEE NAGPUR THROUGH ITS AUTHORISED MEMBAR SHRI DILIP KRISHNARAO MOHADIK has now requested the "Lessor" to execute a new lease to him/her in accordance with the said convent, know all men by these presents that the "Lessor" here by demises to the "Lessee" all the aforesaid plot of land.

To hold the same in continuation of the original lease-deed for the second term commencing from the 09th day of MAY-2016 and ending on 08th day of MAY-2046 subject to the following conditions:-

TERMS AND CONDITIONS

- (a) That, the "Lessee" shall pay the yearly ground rent of Rs. 73440.00 (Rupees in Word Seventy Three Thousand Four Hundred Forty Rupees Only) on the undivided leasehold share of land and clear of all deduction on or before the first day of June in each year at the office of Nagpur Improvement Trust, Nagpur the "Lessor", during subsistence/continuance of the lease may revise the ground rent as per policy framed by the Board of Nagpur Improvement Trust, Nagpur as well as Government and shall be binding on "Lessee" and the "Lessor" has to pay such enhanced ground rent to the "Lessor" without any default or demur.
- (b) The first of such payment is to be made on the first day of June 2017. The "Lessee" at present Pays Rs. 427571.00 as prevailing Corporation Taxes per annum. Total annual average rent is Rs. 501011.00 per annum.
- (c) The "Lessee" shall pay corporation taxes as assessed by the Nagpur Municipal Corporation from time to time, N.A. assessment and any other taxes, levies charges whatsoever.
- (d) The "Lessee" shall not make any excavation upon any part of the said land or remove any stone, sand, gravel, bay or earth there from except for the purpose of forming the foundation or building or for the purpose of executing any work pursuant to the terms of this LEASE and in doing so the LESSEE shall exercises reasonable care to ensure that foundations of any building on the adjoining plots are not hereby adversely affected.
- (e) No erection re-erection or alteration shall be made in any building or part thereof on the said land except in accordance with the sanction of the Nagpur Improvement Trust under its Building Regulations and Development Control Rules, nor shall a building be put to any use in contravention of the provisions of any regulation made under clause (h) of section 90 of the Nagpur Improvement Trust Act, 1936.
- (f) That, after the expiry of the initial period of 30 years, at the time of every renewal of lease, the LESSEE/ASSIGNEE shall be liable to pay three (3) times minimum of existing ground rent after the expiration of every 30 years lease period in respect of demised plot at the time of renewal. The rate of the ground rent due shall be fixed as per the decision of the Trust/LESSOR.

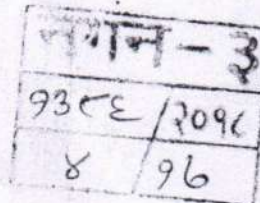

(g) The LESSEE/ASSIGNEE shall take the building permission from Appropriate Planning Authority, for the construction of building before starting constructions on the demised land. The construction of the building should be as per the sanctioned plan approved by the Planning Authority. If any permission for multistoried building was granted, in that case, the Deed of Declaration should be in accordance with the sec. 4, 10, 11, 12 of the Maharashtra Apartment Ownership Act, 1970 and got registered.

(h) If the demised land is subjected for the development wherein the LESSEE executes the development agreement with the DEVELOPER/BUILDER under this circumstances after the completion of entire project the re-conveyance deed shall be executed by the DEVELOPER/BUILDER in favour of the LESSEE/ASSIGNEE/SOCIETY/ASSOCIATION as per the provisions of Registration Act and other relevant laws.

Provided any documents related with the lease plot should be registered before the Registrar under the relevant provisions of Registration Act, 1908 shall be treated as a valid document of evidence of title of LESSEE/ASSIGNEE.

(i) The LESSEE shall permit the LESSOR, or any servant of the Nagpur Improvement Trust at all reasonable time of the day during the terms hereby granted to enter into and upon the demised premises and to inspect the site for repairs thereof and if upon such inspection it shall appear that any repairs are necessary the LESSOR may direct the LESSEE to execute the repairs and upon his failure to do so within a reasonable time to execute them at the expense in all respects of the LESSEE.

(j) The LESSEE shall permit the LESSOR or any person nominated by it or any servant or contractor of the Nagpur Improvement Trust, the Nagpur Corporation and Maharashtra State Electrical Board to enter into and upon the demised premises with such workmen, as may be necessary for the purpose of laying repairing or replacing a water pipe line, sewer line or an electric supply line or for any work connected therewith, as also for the purpose of making any connection from the house to those service lines laid in the premises.

(k) The LESSEE shall not disturb or build over or otherwise deal with so as to impair utility without previous permission of the LESSOR on survey marks or sub traverse make existing on the land which are for clearness shown 'Nil' on the plan hereto annexed and which are specified in Schedule 'B' hereunder written.

(l) The LESSEE shall not disturb or build over or otherwise deal with or interfere with any of the service lines, referred to in sub-clause (c) without the previous permission in writing of the authority which laid the service line.

(m) The LESSEE shall not assign transfer or part with the possession of the demised premises so as to cause any sub-division therein or otherwise to alter nature of this present demise.

Provided however, that the LESSOR may subject to such terms and conditions, as it may fix grant permission to the LESSEE to part with permission of the demised premises so as to cause any subdivision therein, otherwise alter the nature of this present demise.

नान-३	
१३५६	२०१८
५	१६



02  
Dr. Y. Waraj D. Kale  
M.S. Shalaky (Ayu)  
Principal

Provided further that, where sub-division of the demised plot is permissible as per the rules and LESSEE with an intention to sub-divide the demised plot and applies for sub-division and the permission to transfer/assign the sub-divide the demised plot and when such permission is granted the LESSEE shall have to pay 50% of the unearned income if the transfer/assignment is/was made within five years from the date of sub-division of plot, the unearned income shall be payable as per difference between premium paid and the market price of the land prevailing on the date of sale. In case there is dispute regarding market price of sub-divided plot, the decision of the Chairman shall be conclusive and final and binding to the LESSEE

(n) The LESSEE shall not without the previous permission in writing of the LESSOR, use or allow to be used the premises of the demised land in contravention of the regulation framed u/sec. 90 of the Nagpur Improvement Trust Act, 1936 and Development Control Rules.

(o) The LESSEE as also the assignee and the mortgagor/mortgage shall within one month of assignment, mortgage or transfer of the demised premises deliver a notice of such of assignment, mortgage or transfer to the LESSOR setting for the names and description of the parties to every such assignment, mortgage or transfer and particular and the effect thereof.

(o-1) The LESSOR, in case the notice referred to in sub-clause (o) is delivered to it, shall intimate to the LESSEE, assignee, and mortgagee or transferee about arrears of the trust due and its right of re-entry repossession over the demised premises to remedy breach of any or all clauses of condition of lease within a period of the three month of the date of the intimation of that effect.

(p) The LESSEE shall use demised land/plot as per allotment order. If, the LESSEE/ASSIGNEE use the demised land other than that of order as per allotment it is to be treated as breach of condition of the Lease Deed under this circumstances the LESSEE/ASSIGNEE shall be liable for action for cancellation of lease or penalty as per the prevailing Law/Rules & regulation.

(q) This INDENTURE of LEASE the conditions and terms contained therein would be subject to Nagpur Improvement Trust Land Disposal Rules 1983, which has overriding effect and further that if the plot is allotted on concessional rates additional conditions mentioned in Rules 24,16 & 20 including any amendments therein from time to time would be applicable.

(q-1) The plot is allotted on the concessional premium and hence condition as described under Rules 24,16 & 20 including any amendments therein from time to time of the Nagpur Improvement Trust Land Disposal Rules, 1983 and as may be imposed by the Chairman shall be applicable.

(r) The decision of the LESSOR or any person it may appoint in this behalf on any question, which may arise, concerning any alleged breach of any of the foregoing clauses shall be final.

(s) The LEASE of demised land shall be suspended or cancelled, if the LESSEE/ASSIGNEE files any false information/documents regarding title acquired by him/her.

747-3	
9355/2096	
2	96



(t) The LESSOR covenants that the LESSEE paying the rent thereby reserved and performing and observing the conditions herein contained shall peaceably hold and enjoy the said land during the said term without any lawful interruption or disturbance by the LESSOR or any person lawfully claiming through it.

Provided that if the said rent or any part thereof shall at any time be in arrears and unpaid for one Calendar month next after the date where on the same shall have become due whether they shall have been lawfully demanded or not, as also upon the breach or non-observance by the LESSEE of any of the said conditions, the LESSOR may notwithstanding the waiver of any previous causes or right of re-entry upon the said land and reposes it as if this demise had been made the LESSEE in such case being entitled within three Calendar months from the date of such re-entry.

Provided further that when any cause or right of re-entry arise under the foregoing provision, it shall be lawful for the LESSOR, as the consideration for the non-exercise of the power of re-entry to receive from the LESSEE a sum of money not exceeding Two years ground rent plus interest @ 12% p.a. or as may be decided from time to time shall levied in case of payment of ground rent made after due date i.e. 1st of June of each year.

Provided also that when any cause or right off re-entry arises under the first provision, upon the breach or non-observance of the conditions of clause and sub clauses, thereof in respect of erection or alternation, it shall be lawful for the LESSOR to ask the LESSEE to demolish or alter the unauthorized construction, as it may deem necessary, within reasonable time, as a consideration for the non-exercise of the power of re-entry instead of receiving a sum of money as provided above.

(u) That, in case of any dispute between the LESSOR AND LESSEE regarding the breach of any term or condition of the Lease Indenture, the decision of the Chairman of LESSOR shall be final and binding on the parties.

(v) The LESSEE/ LESSESS, has/have read and understood the provisions of the Land Disposal Rules and agrees to abide by the provisions of Land Disposal Rules 1983, terms and conditions of this lease and the Resolutions passed/Policies framed by the LESSOR from time to time.

The LESSOR further covenants that, after the expiry of lease period, lease may be renewed as per the prevailing Rules & Regulations and policies framed by Nagpur Improvement Trust, Nagpur at the time of subsequent lease renewal.

This lease deed is being executed subject to decision of PIL 2227/2004 Shri Wadpalliwar -vs- NIT., Maharashtra State and others.

ना.न-३	
१३८६	२०१८
६	१६



Dr. Yuwara D. Kale  
M. S. Shalakyā (Ayu)  
Principala  
B/M

(6)

'SCHEDULE 'A''

LAND IN WATHODA STREET SCHEME

N.I.T. Kh.No. 321 Mouza Nagpur layout/ Precinct  
Nagpur / Ward No. 20 Division SOUTH Tahsil, and District Nagpur.  
Admeasuring 66078.820 Sq.Meter 711272.00 Sq.ft Dimensions are marked on  
plan enclosed.

Sheet No. 249

City Survey No. 101

USER OF PLOT : PUBLIC UTILITY  
(As Per Allotment)

Boundaries:-  
NORTH - NAG.RIVER & LAND  
SOUTH - ROAD  
EAST - LAND  
WEST - NANDANWAN SLUM

'SCHEDULE 'B''

NIL

In witness where of the parties here to have set their hands the day and year written  
in each case.

Witness :-



*[Signature]*

1st Witness :-



*[Signature]*  
Executive Officer

Nagpur Improvement Trust  
LESSOR

Date 12/4/2018



*[Signature]*

2nd Witness :-



*[Signature]*

LESSEE

Date 12/4/2018

नगन-3	
935E	209C
5	96





**भारत सरकार**  
**Government of India**

**दिलीप कृष्णराव महाडिक**  
 Dilip Krushnrao Mahadik  
**जन्म तारीख / DOB : 28/05/1945**  
 पुरुष / Male



**9603 9239 4212**

**आधार - सामान्य माणसाचा अधिकार**

**भारतीय विशिष्ट ओळख प्राधिकरण**  
**Unique Identification Authority of India**

**पत्ता प्लॉट न 342/733 सी, पी.टी. मास्से मार्ग, टीकाभूमी समोर, लक्ष्मी नगर, राणाप्रताप नगर, राणाप्रताप नगर, नागपूर, महाराष्ट्र, 440022**

**Address: plot no 342/733 C, P.T. masse marg, opposite dikshabhumi, laxmi nagar, Ranapratap Nagar, Ranapratap Nagar, Nagpur, Maharashtra, 440022**

**9603 9239 4212**





*Handwritten signature*

**नगन-३**

93	2096
99	96



**स्थायी लेखा संख्या / PERMANENT ACCOUNT NUMBER**  
**AAATB1267E**

**नाम / NAME**  
**BACKWARD CLASS YOUTH RELIEF COMMITTEE**

**निगमन/बनने की तिथि / DATE OF INCORPORATION/FORMATION**  
**24-09-1974**

  
**COMMISSIONER OF INCOME TAX, VIDARBH.**

*Handwritten number 62 in a circle*

**Dr. Yuwara D. Kale**  
**M.S. Shalakyā (Ayu)**  
**Principal**  
**B.M. ...**



भारतीय विशिष्ट ओळख प्राधिकरण  
भारत सरकार  
Unique Identification Authority of India  
Government of India

नोंदविपयाचा क्रमांक / Enrollment No.: 1207/13526/01418

To  
रमेश चिंधेराव मुळक  
Ramesh Chindherao Mulak  
near kdk boy hostel flat no m101 maa durga society  
nandanavan  
Hanuman Nagar S.O  
Hanuman Nagar  
Nagpur  
Maharashtra 440009  
8087338313  
382572177  
MA825721779FT



भारतीय विशिष्ट पहचान प्राधिकरण  
UNIQUE IDENTIFICATION AUTHORITY OF INDIA

पत्ता:  
S/O रमेश साठेने, फ्लॉट नं.  
४-ए, अरुणोदय, तिरुपती  
बँक मार्गे, विजयानंद  
मोसायटी, नॅट्र नगर,  
नागपूर, नागपूर,  
महाराष्ट्र - 440015

Address:  
S/O Ramesh Satone, Flat No. 4A,  
Arundodaya, Baling Tirupati Bank  
Vijayanand Society, Nandana Nagar  
Nagpur, Nagpur,  
Maharashtra - 440015

6408 4106 3081

Aadhaar-Aam Admi ka Adhikar

आपला आधार क्रमांक / Your Aadhaar No. :

4612 8180 2119

माझे आधार, माझी ओळख



भारत सरकार  
Government of India

रमेश चिंधेराव मुळक  
Ramesh Chindherao Mulak  
जन्म तारीख / DOB: 15/03/1946  
पुरुष / Male



4612 8180 2119

माझे आधार, माझी ओळख

*Signature*



भारत सरकार  
GOVERNMENT OF INDIA



स्वप्नील रमेश साठेने  
Swapneel Ramesh Satone  
जन्म तारीख / DOB: 11/02/1980  
पुरुष / MALE



6408 4106 3081

आधार-सामान्य माणसाचा अधिकार

*Signature*

नगन-३  
१३८६/२०१८  
१२/१७



1414266  
13/04/2018

## नोंदणीपुर्व गोषवारा

दुय्यम निबंधक : सह.दु.नि. नगन3  
एन्टी क्रमांक : 1414/2018

- (1) विलेखाचा प्रकार  भाडेपट्टा
- (2) मोबदला रु. 0
- (3) बाजारभाव रु. 10122000
- (4) आवश्यक मुद्रांक शुल्क रु. 455490
- (5) दस्त निष्पादित केल्याचा दिनांक 12/04/2018
- (6) गावाचे नाव नागपूर (खास)-- नागपूर म.न.पा.
- (7) पृष्ठांची संख्या 16
- (8) भू-मापन, पोटहिस्सा व घरक्रमांक (असल्यास) 1) C.T.S. Number : 101 ;
- (9) मालमतेचे इतर वर्णन 1), इतर माहिती: मौजा नागपूर वाई नंबर 20 खसरा नंबर 321 जागा एकुण क्षेत्र 66078.820 चौ.मी. शिट नंबर 249 सिटीएम नंबर 101.

- 1) ही माहिती पक्षकारांनी सश्रांकित केलेल्या इनपुट फॉर्मवर आधारित आहे.
- 2) दस्ताची माहिती संगणकावर घेण्यात आली. याचा अर्थ दस्त नोंदणीसाठी स्वीकारला असा नाही. दुय्यम निबंधक दस्त नाकारू शकतात किंवा नियमानुसार योग्य ती अन्य कार्यवाही करू शकतात.
- 3) बदल/दुरुस्त्या कराव्यात, लागू नसलेला मजकूर सोडावा.

9306/94

(10) क्षेत्रफळ 1) 66078.82 चौ.मीटर

(11) दस्तऐवज करून देणाऱ्या / लिहून देणाऱ्या पक्षकाराचे नाव व पत्ता

- 1) बॅकवर्ड क्लाम युथ रिलिफ कमिटी नागपूर तर्फे अधिकृत मेंबर दिलीप कृष्णराव महाडीक . वय:-72 पत्ता:-, , , , , , केडीके कॉलेज आफ इंजिनिरिंग ग्रेट नाग रोड नंदनवन नागपूर 9890020856, ईमः ऑरि नाका , MAHARASHTRA, NAGPUR, Non-Government. पिन कोड:-440009 पॅन नं:-AAATB1267E
- 1) backward class youth rilif committee nagpur tarfe adhikrut member dilip krushnarao mahadik . . Age:-72 Address:-, , , , , , Kedike Kolej APh Injining Gret Nag Rod Nandanavan Nagapur 9890020856 , DIGHORI NAKA, MAHARASHTRA, NAGPUR, Non-Government. Pin Code:- 440009 Pan No.-AAATB1267E

(12) दस्तऐवज करून घेणाऱ्या / लिहून घेणाऱ्या पक्षकाराचे नाव व पत्ता

- 1) नागपूर सुधार प्रन्यास, नागपूर कार्यकारी अधिकारी, श्री प्रशांत मनोहरराव भांडारकर यांचे तर्फे कबुलीजबाब देणारा श्री राजेश मधुकर समरित . . वय:-53; पत्ता:- फ्लॉट नं: .. माळा नं: .. इमारतीचे नाव: .. ब्लॉक नं: .. रोड नं: नागपूर सुधार प्रन्यास, कार्यालय, सदर नागपूर, महाराष्ट्र, नागपूर. पिन कोड:-440001 पॅन नं:-
- 1) nagpur sudhar pranyas, nagpur karyakari adhikari, shri prashant manoharao bhandarkar yanche tarfe kabulijabab denar shri rajesh madhukar samrit . . Age:-53 Address:-Flat No.: .., Floor No.: .., Building: .. Block Sector: .., Road: nagpur sudhar pranyas, karyalay, sadar nagpur, State: MAHARASHTRA, District: NAGPUR. Pin Code:-440001 Pan No.:-

(13) ओळख देणाऱ्यांचे तपशील

- 1) म्वप्रील रमेश साटोने . . वय:-38 पत्ता:- विजयानंद सोसायटी नरेंद्र नगर नागपूर पिन कोड:-440009
- 1) swapnil ramesh satone . . Age:-38 Address:-vijayanand society narendra nagar nagpur PIN Code:-440009
- 2) रमेश चिन्हेराव मुळक . . वय:-72 पत्ता:- मा दुर्गा सोसायटी, नंदनवन नागपूर पिन कोड:-440009
- 2) ramesh chindherao mulak . . Age:-72 Address:-maa durga society, nandanvan nagpur PIN Code:-440009

नगन-३  
9306/2096  
93/96



नोंदणीपुर्व गोषवान्यामध्ये इनपुट फॉर्म प्रमाणे अचूक डाटा एन्ट्री करण्यात आली आहे.

नोंदणीपुर्व गोषवारा तपासून पाहिला. तो बरोबर आहे/त्याच्यात नमुद केलेल्या दुरुस्त्या कराव्यात.

( डाटा एन्ट्री ऑपरिटर स्वाक्षरी )

पक्षकाराची स्वाक्षरी )

नोंदणीपुर्व गोषवारा इनपुट फॉर्म प्रमाणे आहे व याचा मेळ मुळ दस्ताशी घेण्यात आला आहे. पक्षकाराने नमुद केलेले बदल/दुरुस्त्या याचा समावेश करण्यात आला आहे.

( NGP3 स्वाक्षरी )



मुल्यांकनासाठी विचारात घेतलेला तपशील: ..... दस्तप्रकारनुसार आवश्यक नाही ..... दस्तप्रकारनुसार आवश्यक नाही)

मुद्रांक शुल्क आकारताना निवडलेला अनुच्छेद: (i) within the limits of any Municipal Corporation or any Cantonment area annexed to it. ( 84 )

दस्त भारतात आल्याचा दिनांक: \_\_\_\_\_

Note Exemption Under 88:-(#) , sign of party:-(£) , दस्त नोंदणीनंतर आपणास मूळ दस्त व थंबनेल प्रिंट मिळेल.

#### Seller Details

SR. NO.	Khata No.	Property No.	Party Name	Navi Area	Vikri Area	Navi Potkharab	Vikri Potkharab
1	0	-	नागपूर सुधार प्रन्धाम, नागपूर कार्यकारी अधिकारी, श्री प्रशांत मनोहरराव भांडारकर यांचे तर्फे कमुली जवाब देणार श्री राजेश मधुकर समरीत .	0.0	0.0	0.0	0.0

#### Buyer Details

SR. NO.	Khata No.	Property No.	Party Name	Kharidi Area	Kharidi Potkharab	Seller Khata No.	Seller Name
1	0	-	वैकवई क्लाम युथ रिलिफ कमिटी नागपूर तर्फे अधिकृत मॅबर दिलीप कृष्णराव महाडीक .	0.0	0.0	0	

नगन-३  
93८६/२०१८  
१४/१७



Dr. Yuwaraj B. Kale  
M.S. Shalakyā (Ayu)  
Principal  
B.I.



**CHALLAN**  
MTR Form Number-6

GRN	MH008219511201718E	BARCODE			Date	13/12/2017-14:21:03	Form ID	36
Department					Inspector General Of Registration			
Type of Payment					Stamp Duty Registration Fee			
Office Name					NGP1_HQR SUB REGISTRAR NAGPUR 1			
Location					NAGPUR			
Year					2017-2018 One Time			
Account Head Details					Amount In Rs.			
0030046401 Stamp Duty					506100.00			
0030063301 Registration Fee					30000.00			
Flat/Block No.					KH NO 321			
Premises/Building					MAUZA NAGPUR			
Road/Street					NAGPUR			
Area/Locality					NAGPUR			
Town/City/District					NAGPUR			
PIN					4 4 0 0 0 1			
Remarks (If Any)					PAN2=AAATB1367E-SecondPartyName=NAGPUR IMPROVEMENT TRUST-CA=1-Marketval=1			
Amount In					Five Lakh Thirty Six Thousand One Hundred Rupees O			
Words					nly			
Total					5,36,100.00			
Payment Details					STATE BANK OF INDIA			
Cheque-DD Details					FOR USE IN RECEIVING BANK			
Bank CIN					Ref. No. 00040572017121337080 CKE3884768			
Bank Date					RBI Date 13/12/2017-02:21:50 14/12/2017			
Name of Bank					Bank-Branch STATE BANK OF INDIA			
Name of Branch					Scroll No. , Date 348 , 14/12/2017			



NOTE:- This challan is valid only if registered in Sub Registrar office only. Not valid for unregistered document. Mobile No. : Not Available  
सदर चालन केवल दुरु लखत नोदणी करावयाच्या दस्तावाठी लागू आहे. नोदणी न करावयाच्या दस्तावाठी सदर चालन लागू नाही.

Digitally signed by  
VIRTUAL TREASURER  
MUMBAI 01  
Date: 2018.04.13  
10:12:41 IST  
Challan Defacement Report Secure Document  
Location: India

Sr. No.	Remarks	Defacement No.	Defacement Date	Userid	Defacement Amount
1	(IS)-266-1386	0000287912201819	13/04/2018-10:12:40	IGR385	30000.00

नगण-३  
93KE/209C  
94/96



Print Date 13-04-2018 10:12:41  
Dr. Yuvraj B. Kale  
Mrs. Shalabya Ayu  
Principal

266/1386

शुक्रवार, 13 एप्रिल 2018 10:13 म.पू.

दस्त गोपवारा भाग-1

नगन3 9E-96  
दस्त क्रमांक: 1386/2018

दस्त क्रमांक: नगन3 /1386/2018

वाजार मूल्य: रु. 1,01,22,000/- मोबदला: रु. 00/-

भरलेले मुद्रांक शुल्क: रु.5,06,100/-

दु. नि. सह. दु. नि. नगन3 यांचे कार्यालयात

अ. क्र. 1386 वर दि.13-04-2018

रोजी 10:01 म.पू. वा. हजर केला.

पावती:1899

पावती दिनांक: 13/04/2018

सादरकरणाचा नाव: वॅकवर्ड क्लाम युथ रिलिफ कमिटी नागपूर तर्फे  
अधिकृत मेंबर दिलीप कृष्णराव महाडीक ...

नोंदणी फी	रु. 30000.00
दस्त हाताळणी फी	रु. 340.00
पृष्ठांची संख्या: 17	

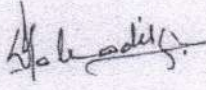

दस्त हजर करणाऱ्याची मही.

एकूण: 30340.00



सह दुय्यम निबंधक, वर्ग-२

नागपूर शहर क्र. ३.

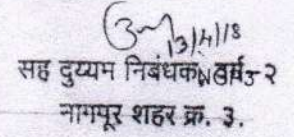

सह दुय्यम निबंधक वर्ग-२  
नागपूर शहर क्र. ३.

दस्ताचा प्रकार: भाडेपट्टा

मुद्रांक शुल्क: (एक) कोणत्याही महानगरपालिकेच्या हद्दीत किंवा स्थालगत असलेल्या कोणत्याही कटक क्षेत्राच्या हद्दीत किंवा उप-खंड (दोन) मध्ये नमूद न केलेल्या कोणत्याही नागरी क्षेत्रात

शिक्षा क्र. 1 13 / 04 / 2018 10 : 01 : 02 AM ची वेळ: (सादरीकरण)

शिक्षा क्र. 2 13 / 04 / 2018 10 : 03 : 00 AM ची वेळ: (फी)

Dr. Yurwaraj D. Kale  
M. S. Shalakra (Ayu)  
B.M. ...



13/04/2018 10 15:06 AM

दस्त गोषवारा भाग-2

नगन3 96-96

दस्त क्रमांक:1386/2018

दस्त क्रमांक :नगन3/1386/2018

दस्ताचा प्रकार :-भाडेपट्टा

अनु क्र.	पक्षकाराचे नाव व पत्ता	पक्षकाराचा प्रकार	छायाचित्र	अंगठ्याचा ठसा
1	नाव:बॅकवर्ड क्लास युथ रिलिफ कमिटी नागपूर तर्फे अधिकृत मॅबर दिलीप कृष्णराव महाडीक पत्ता:....., केडीके कॉलेज आफ इंजिनियरिंग ग्रेट नाग रोड नंदनवन नागपूर 9890020856, डीग:आरी नाका MAHARASHTRA, NAGPUR, Non- Government. पॅन नंबर:AAATB1267E	भाडेकरू वय :-72 स्वाक्षरी:- 		
2	नाव:नागपूर सुधार प्रन्यास, नागपूर कार्यकारी अधिकारी, श्री प्रशांत मनोहरराव भांडारकर यांचे तर्फे कबुलीजवाब देणार श्री राजेश मधुकर समरीत पत्ता:प्लॉट नं. .. माळा नं. .. इमारतीचे नाव: .. ब्लॉक नं. .. रोड नं. नागपूर सुधार प्रन्यास, कार्यालय, सदर नागपूर, महाराष्ट्र, नागपूर. पॅन नंबर:	मालक वय :-53 स्वाक्षरी:- 		

बरील दस्तऐवज करून देणार तथाकथीत भाडेपट्टा चा दस्त ऐवज करून दिल्याचे कबुल करतात.  
शिक्का क्र.3 ची वेळ:13 / 04 / 2018 10 : 04 : 00 AM

सह दुय्यम निबंधक, वर्ग-२  
नागपूर शहर क्र. ३.

ओळख:-

खालील इसम असे निवेदीत करतात की ते दस्तऐवज करून देणा-यानां व्यक्तीशः ओळखतात, व त्यांची ओळख पटवितात

अनु क्र.	पक्षकाराचे नाव व पत्ता	छायाचित्र	अंगठ्याचा ठसा	
1	नाव:स्वप्नील रमेश साटोने वय:38 पत्ता:विजयानंद सोसायटी नरेंद्र नगर नागपूर पिन कोड:440009	स्वाक्षरी 		
2	नाव:रमेश चिन्धेराव मुळक वय:72 पत्ता:मा दुर्गा सोसायटी,नंदनवन नागपूर पिन कोड:440009	स्वाक्षरी 		

शिक्का क्र.4 ची वेळ:13 / 04 / 2018 10 : 04 : 43 AM

शिक्का क्र.5 ची वेळ:13 / 04 / 2018 10 : 04 : 57 AM नोंदणी पुस्तक 1 मध्ये

NGP3

सह दुय्यम निबंधक, वर्ग-२

नागपूर शहर क्र. ६ Payment Details.

प्रमाणित करण्यात येते कि, या दस्ताऐवजात  
एकूण १६ पाने आहेत.

१ नंबराचे बुकाचे  
१३८६ नंबरी नोंदला

सह दुय्यम निबंधक वर्ग-२,  
नागपूर शहर क्र. ३,  
दि. १३. माहे. ०४. सन २०१८

सह दुय्यम निबंधक वर्ग-२,

नागपूर शहर क्र. ३

sr. Epayment Number

1 MH008219511201718E

Defacement Number

0000287912201819

1386 / 2018

1. Verify Scanned Document for correctness through human (4 pages on a side) printout after scanning.  
2. Get print immediately after registration.



Dr. Yuvaraj D. Kale  
M.B. Shalakra (Ayu)  
Firozpur  
B.M. ...



2025-2026

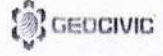

नागपूर महानगरपालिका  
कर व कर आकारणी विभाग नागपूर

(हि रसिद 01/04/2025 पासून 31/03/2026 पावेतो वापरली जाईल. त्यापुढे वापरत्यास ती खोटी समजावी)

रसिद क्रमांक: RCPT2526186392 मोहल्याचे नांव: SAKKARDARA  
ZONE 2

घर क्रमांक: 1128/L

पूपीन: 0200110001 इंडेक्स क्रमांक: 20007129

घर मालकाचे नांव: PRESI. BACKWARD CLASS YOUTH RELIF COMMITTEE TO SHRI  
BABASAHEB KAMMAWAR ENG. COLLEGE NAGPUR.

वहिवाटदाराचे नांव :

घरचा पत्ता: 1128/L, SAKKARDARA ZONE 3 440001

तारीख पासून : 01-04-2025 ता 31-03-2026 पावेतो

कराचे नांव/ Details of Tax	बकाया/ Arrears	चातु/ Current	शेरा/ Remarks
सामान्य कर (General Tax)	0	0	
पाणी कर (Water Tax)	0	0	
मलजल कर (Sewerage Tax)	0	341900	
प्रकाश कर वृक्ष कर (Light Tax/Tree Tax)	0	28494	
अग्नी सेवा कर (Fire Service Tax)	0	28494	
मलजल लाभ कर (Sewerage Bene. Tax)	0	28494	
पाणी लाभ कर (Water Bene. Tax)	0	28494	
पथ कर (Street Tax)	0	0	
विशेष सफाई कर (Special Conservancy Tax)	0	0	
मनपा शिक्षण उपकर (Municipal Education Tax)	0	0	
सेवा शुल्क (Service Charge)	0	0	
नोटीस फी (Notice Fee)	0	0	
वारंट फी (Warrant Fee)	0	0	
किरकोळ (Misc.)	0	0	
रा.स.शी.कर (Educn. Cess)	0	0	
रोजगार हमी कर (E.G.S. Cess)	0	0	
मोठ्या निवासी इमारतीवरील शासनाचा कर (Tax on Larger Residential Properties)	0	284920	
सुट (Rebate)	0	68382	
एकूण (Grand Total)	0	672414	

एकूण रक्कम अक्षरी रू (In words total Rs.) SIX LAKH SEVENTY-TWO THOUSAND FOUR HUNDRED AND FOURTEEN RUPEES ONLY

Received Amount : ₹672,414.00

(Payment is made by Online)

Transaction No. : BCPN8KF0ONWXNY

Transaction Date: 2025-06-27T15:10:34+05:30

दिनांक: 27/06/2025

वसूल करणाराची पूर्ण सही

Generated By: NMC-CITIZEN

Full Signature of the Official

This is a computer generated receipt, signature is not required. Please visit website <http://www.nmcnagpur.gov.in>

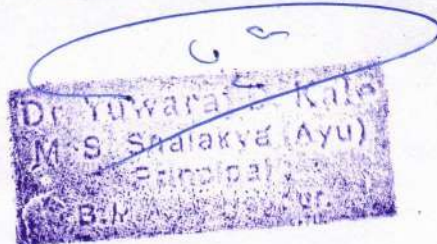

B-5



# NAGPUR IMPROVEMENT TRUST

Station Road, Sadar, Nagpur-440 001

Phone No. 2533202, P.B.X. 253143, 2531432, Fax No. 0712 2531079

No:- D.D.T.P./Planning/ 915

Date:- 10/05/2023

To,

✓ The Principal  
K.D.K. College,  
Nagpur

**Subject :-** Request for issue of following certificate for submission to AICTE, New Delhi

- Land Use certificate
- Land Conversion certificate
- Land classification certificate (Mega/Metro/Urban/Rural)
- FSI as on date certificate

**Reference :-** Your letter no. KDKCE/1017/2023 dated :- 10/05/2023

With reference to above mentioned subject and referred letter dated 10/05/2023, you have requested these offices to issue the following documents required to submit in AICTE, New Delhi.

- Land Use certificate
- Land Conversion certificate
- Land classification certificate (Mega/Metro/Urban/Rural)
- FSI as on date certificate

Following are the details of the land bearing Kh. No. 321, Mouza Nagpur, Area 66,078.82 Sqmt.

- **Land Use and Land Conversion Certificate :-** The Revised Development Plan of Nagpur city prepared under the provisions of Maharashtra Regional and Town Planning Act, 1966 have been sanctioned by Government vide Urban Development Deptt. Notification No. TPS-2496-2643-CR-300(a)97-UD-9, dated the 7th January 2000 and finally sanctioned by Government vide, Notification No. TPS-2400-1628-CR-2000-UD-9, dated the 10th September 2001. As per Sanctioned Revised Development Plan of Nagpur city on dated 10/09/2001, the said land bearing Kh. No. 321, Mouza Nagpur, area 66,078.82 Sqmt. is shown as "Public-Semi Public Zone" and in Public-Semi public zone, Educational complex use is permissible. The said land is designated as "K.D.K Engineering College" in the said Development Plan of Nagpur city.
- **Land classification certificate (Mega/Metro/Urban/Rural) :-** The said land bearing Kh. No. 321, Mouza Nagpur, area 66,078.82 Sqmt. fall under Nagpur Urban area within Nagpur Municipal Corporation limit. The Nagpur Municipal Corporation is the 'Planning Authority' for the said area.
- **FSI as on date certificate: -** As per Sanctioned Unified Development Control and Promotions Regulations of dated 02/12/2020 (the regulations comes in-force from 03/12/2020), as per clause no. 6.3 Table 6G, the basic FSI of said plot is 1.10. As the said land is situated on 30.00 mt. wide Great Nag Road, and as per Table 6G of UDCPR-2020, the maximum building potential on plot including in situ FSI shall be 3.00.

Note:- This certificate is issue on request of your letter dated 10/05/2023

(Approved by Hon. Chairman, NIT, Nagpur)

Encl:- As above

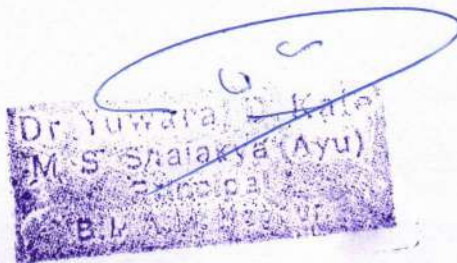

Deputy Director Town Planning  
Nagpur Improvement Trust  
Nagpur

DEVENDRAPRA  
TAP BAIJNATH  
SINGH

Digitally signed by DEVENDRAPRA  
BAIJNATH SINGH  
DN: c=IN, o=Personal, title=653L  
pseudonym=133247375101348998DX, Aquu  
m74899#  
1.5.4.2001.101.101.75ab8d7b45c5e51c75c39c8d0  
85246fcdca77135600f4e098a2c0b73f  
postalCode=440025, st=Maharashtra,  
serialNumber=1.0774467902f95399a8b8b6  
1ee09401de7a5246582f16d1181988f73851b  
cn=DEVENDRAPRA BAIJNATH SINGH  
Date: 2023.05.12 12:32:02 +05'30'

1. These Unified Development control and Promotion Regulations are sanctioned by the State Government under Section 37(IAA)(c) and Section 20(4) of the Maharashtra Regional & Town Planning Act, 1966 vide Notification No.TPS-1818/CR-236/18/DP&RP/Sec.37(IAA)(c) & Sec.20(4) UD-13, Dated 02 December, 2020.
2. These Unified Development control and Promotion Regulations are published by the State Government under Section 20(3) of the Maharashtra Regional & Town Planning Act, 1966 vide Notice No.TPS-1818/CR-236/18/Sec.20(3)/UD-13, Dated 02 December, 2020.
3. Directives under Section 154 of the Maharashtra Regional & Town Planning Act, 1966 issued by the State Government vide Resolution No.TPS-1818/CR-236/18/Sec.20(3)/UD-13, Dated 02 December, 2020.
4. These Unified Development control and Promotion Regulations are published by the State Government under Section 37(IAA)(c) of the Maharashtra Regional & Town Planning Act, 1966 vide Notification No.TPS-1818/CR-236/18/Sec.37(IAA)/UD-13, Dated 02 December, 2020.
5. Directives under Section 154 of the Maharashtra Regional & Town Planning Act, 1966 issued by the State Government vide Resolution No.TPS-1818/CR-236/18/Sec.37(IAA)/UD-13, Dated 02 December, 2020.

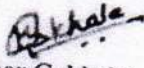
  
(Kishor Gokhale)  
Under Secretary  
Government of Maharashtra

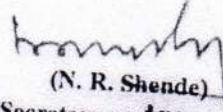
  
(N. R. Shende)  
Joint Secretary and Director of Town Planning  
Government of Maharashtra

  
Dr. Yuwaraj S. Kale  
M. S. Shalabya (Ayu)  
B.M. Shalabya (Ayu)

DEVENDRA  
PRATAP  
BAIJNATH  
SINGH

Digitally signed by DEVENDRAPRATAP  
BAIJNATH SINGH  
DN: cn=N, ou=Personal, title=ESR,  
pseudonym=13324737510134896DLA,  
gnunet/4896f,  
2.5.4.20=03a0775ab8d7b45ce59c75c39c,  
d0b08524664dc77f55084a098a2cc,  
06721, postalCode=440025,  
st=Maharashtra,  
serialNumber=01df744d905b9f53996d  
R2b08ee99f070e7a5240582f16d11839  
d8773051b, cn=DEVENDRAPRATAP  
BAIJNATH SINGH  
Date: 2023.05.12 12:32:49 +05'30'

- 6.2.5 In case of group housing scheme where building abuts on internal road, the minimum 3m. set back from internal road or distance between two buildings whichever is more shall be provided. For Development plan road /Regional plan road or classified road or through road, passing through Group Housing Scheme, normal setback as prescribed in the regulations shall be provided.
- 6.2.6 **Buildings Abutting Two or More Streets**  
When a Building abuts two or more streets, the setbacks from the streets shall be such as if the building is fronting on each of such streets.
- 6.3 **PERMISSIBLE FSI**  
Permissible basic FSI, additional FSI on payment of premium, Permissible TDR Loading on a plot in **non-congested** area for **Residential and Residential with mixed uses** and other buildings in developable zones like residential, commercial, public-semi-public etc. shall be as given in Table 6 G below :-

02  
Dr. Yuwaraj D. Kale  
M.S. Shalakra (Ayu)  
Principal  
B.M. ...

DEVENDRAP  
RATAP  
BAIJNATH  
SINGH

Digitally signed by DEVENDRAPRATAP  
BAIJNATH SINGH  
DN: cn=IN, o=Personal, title=6536,  
pseudoym=133247375101348968DX Agux  
km7466947,  
2.5.4.20=03a875ab6d7b45ce59c75c39c2d0  
bb524d6c4dc77f356084fa098a2cc0672f,  
postalCode=440025, st=Maharashtra,  
serialNumber=b1d1744d905b9f5399d88bb  
86fe99f4d7de7a5348582f16d1f839d8f73b  
51b, cn=DEVENDRAPRATAP BAIJNATH  
SINGH  
Date: 2023.05.12 12:33:31 +05'30'

Table 6 G								
Sr. No.	Road width in meters	Basic FSI	For all Municipal Corporations			For remaining authorities/areas		
			FSI on payment of premium	Maximum permissible TDR loading	Maximum building potential on plot including in-situ FSI	FSI on payment of premium	Maximum permissible TDR loading	Maximum building potential on plot including in-situ FSI
			4	5	6	7	8	9
1	2	3	4	5	6	7	8	9
1	Below 9 m.	1.10	--	--	1.10	--	--	1.10
2	9 m. and above but below 12 m.	1.10	0.50	0.40	2.00	0.30	0.30	1.70
3	12 m. and above but below 15 m.	1.10	0.50	0.65	2.25	0.30	0.60	2.00
4	15 m. and above but below 24 m.	1.10	0.50	0.90	2.50	0.30	0.70	2.10
5	24 and above but below 30 m.	1.10	0.50	1.15	2.75	0.30	0.90	2.30
6	30 and above	1.10	0.50	1.40	3.00	0.30	1.10	2.50

Dr. Yuvraj D. Kale  
 M.S. Shalakar (Ayu)  
 B.H. ...

CS

DEVENDRAP  
 RATAP  
 BAJNATH  
 SIMGH

B-6

Backward Class Youth Relief Committee's  
(Recognised by NCISM & Ayush New Delhi and Affiliated to MUHS, Nasik)

**BHAUSAHEB MULAK AYURVED MAHAVIDYALAYA  
& MEDICAL SCIENCE & RESEARCH HOSPITAL (AYU)**

Great Nag Road, Nandanvan, Nagpur - 440009 Ph. No. : 0712-2712740, 2710727



**Smt. Sumanmala Mulak**  
Chairman

**Shri Rajendra Mulak**  
Secretary  
Ex-State Minister of Maharashtra  
Finance & Planning, Energy,  
Water Resources, Parliamentary  
Affair & Excise

**Dr. Yuwaraj D. Kale**  
Principal  
B.M.A.M. Nagpur  
MS (Ayu), Dip (Netra)  
Reg. No. I - 24159 A1

Ref :

Date :

**TO WHOMSOEVER IT MAY CONCERN**

This is to certify that the piece and parcel of land being Nagpur Improvement Trust Leasehold land in Wathoda Street Scheme, admeasuring about 66078.820 Sq Mtrs i.e. 711272.00 Sq ft having user as Public Utility, being portion of Kh. No. 321 of Mauza: Nagpur bearing City Survey No. 101, Sheet No. 249 along with construction bearing House No. 1128/L, Ward No. 20 popularly known as KDK Campus is leased by Nagpur Improvement Trust to Backward Class Youth Relief Committee Reg No. F-1759(N).

Our College is an institution established and owned by said Trust Backward Class Youth Relief Committee and located at the address mentioned above. Title verification and non encumbrance certificate for the said land is attached along with for reference.

**Dr. Yuwaraj D. Kale**  
M.S. Shalakyā (Ayu)  
Principal  
B.M.A.M. & M.S. & R.H. (Ayu)

**Dr. Yuwaraj D. Kale**  
M. S. Shalakyā (Ayu)  
PRINCIPAL  
B.M.A.M. & M.S. & R.H. (Ayu)

S. S. Dwivedi B.A., L.L.B.  
S.M. Khedkar B.com., L.L.B.  
V. G. Dwivedi B.com., L.L.B.  
**ADVOCATES**  
Consultants for transfer of  
Properties & Income Tax

**d k**  
Advocates

Date: 05/12/2024

**TITLE VERIFICATION REPORT  
AND NON ENCUMBRANCES CERTIFICATE**

This is to certify that, We have verified the titles of ALL THAT piece and parcel of land being Nagpur Improvement Trust Leasehold land in Wathoda Street Scheme, admeasuring about 66078.820 Sq. Mtrs. i.e. 711272.00 Sq. Ft., having User as Public Utility, being portion of Kh. No. 321 of Mauza : NAGPUR, bearing City Survey No. 101, Sheet No. 249 alongwith construction bearing Municipal House No. 1128/L, Ward No. 20, known as KDK Collage of Engineering situated at Great Nag Road, Nagpur within the limits of Nagpur Municipal Corporation, Tahsil and District : Nagpur owned by BACKWARD CLASS YOUTH RELIEF COMMITTEE, NAGPUR an institution having registered Office at 1049-1050, Nandanvan Lay Out, Nagpur. That earlier we have issued our Title investigation Report on 06.02.2024, this report is addendum / continuation of the same. There is no change in status. Our findings are as under.

01. That the property in question has been owned by the Nagpur Improvement Trust, Nagpur a statutory body duly incorporated under the provisions of the Nagpur Improvement Trust Act, 1936. The Nagpur Improvement Trust obtained the title on the said Khasara under the Law of Acquisition in pursuance to the Award passed by the Land Acquisition Officer after making the publication of acquisition in the Gazettes and news papers and on payment of compensation payable to the land owners. After acquisition of the said land, Nagpur Improvement Trust, Nagpur developed the said land and made lay out on the said land consisting of various residential plots, open spaces, Public Utility area etc.

02. The Nagpur Improvement Trust, Nagpur out of Wathoda Street Scheme allotted the said N.I.T. land to Backward Class Youth Relief Committee, Nagpur and executed Indenture of Lease dt. 04th day of December 2007 in respect of the said Plot in its favour for a term commencing from 09th day of May 1986 and ending on 08th day of May 2016 registered with Sub Registrar Nagpur - 3 at Book No. 1 at Sr. No. 5429 at 24.12.2007.



**M/s DWIVEDI & KHEDKAR ADVOCATES**

Ground Floor, "Shriniwas", 10, Central Avenue, Wardhaman Nagar Sq., Nagpur - 440006 Ph. No. 0712-2767995  
Email : msdkadvocates@gmail.com , msdkadvocates@yahoo.com



03. That said Backward Class Youth Relief Committee, Nagpur constructed a building on the said plot of land in accordance with the Revised Building plan sanctioned by Sub Divisional Engineer, Town Planning Department, Nagpur Municipal Corporation, Nagpur, vide Building Permit No. 677/BP/Nagpur/TP/NMC/1124 dt. 27.10.2010.

04. The Nagpur Improvement Trust, Nagpur after expire of the original Lease period renewed the Lease of the said land in favour of Backward Class Youth Relief Committee, Nagpur for a further term commencing from 09<sup>th</sup> day of May 2016 and ending on 08<sup>th</sup> day of May 2046 by Indenture of Renewal of Lease dt. 12<sup>th</sup> day of April 2018 registered with Sub Registrar Nagpur - 3 in Book No. 1, at Sr. No. 1386 dt. 13.04.2018.

05. That Backward Class Youth Relief Committee, Nagpur mortgaged the said property with Abhyudaya Co. Operative Bank Limited, Ajani Square Branch, Nagpur for establishment / erection of Infrastructure and Development purpose.

06. We have satisfied that the property is heritable and transferable and the owner has a right to transfer the same. All the necessary parties have been joined and the documents have desired effect. We have also confirmed from the Government and Public Land Acquisition Authorities that the property above mentioned is not subject to any acquisition or requisition from any authorities. We also certify that the Lease Deed/s is/are duly stamped in accordance with the Maharashtra / Bombay Stamp Act, 1958 and necessary Registration Fees is paid under provisions of Indian Registration Act, 1908.

07. The relevant document of titles are genuine. We have verified and tallied the said documents from the records of Registrar of Assurances, Nagpur, Facts and events material to search made by me and the documents placed before me of Nagpur Improvement Trust Leasehold Public Utility Land and the construction thereon, the same is now owned by Backward Class Youth Relief Committee, Nagpur and the same is presently mortgaged with Abhyudaya Co. Operative Bank Limited, Ajani Square Branch, Nagpur for establishment / erection of Infrastructure and Development purpose. as stated hereinabove.

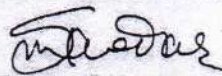
  
(S. M. KHEDKAR)  
ADVOCATE  
05.12.2024





# NAGPUR IMPROVEMENT TRUST

Station Road, Sadar, Nagpur-440 001  
Phone No. 2533202, P.B.X. 253143, 2531432, Fax No. 0712 2531079

No:- D.D.T.P./Planning/ 915

Date:- 10/05/2023

To,  
The Principal  
K.D.K. College,  
Nagpur

Subject :- Request for issue of following certificate for submission to AICTE, New Delhi

- Land Use certificate
- Land Conversion certificate
- Land classification certificate (Mega/Metro/Urban/Rural)
- FSI as on date certificate

Reference :- Your letter no. KDKCE/1017/2023 dated :- 10/05/2023

With reference to above mentioned subject and referred letter dated 10/05/2023, you have requested these offices to issue the following documents required to submit in AICTE, New Delhi.

- Land Use certificate
- Land Conversion certificate
- Land classification certificate (Mega/Metro/Urban/Rural)
- FSI as on date certificate

Following are the details of the land bearing Kh. No. 321, Mouza Nagpur, Area 66,078.82 Sqmt.

- **Land Use and Land Conversion Certificate** :- The Revised Development Plan of Nagpur city prepared under the provisions of Maharashtra Regional and Town Planning Act, 1966 have been sanctioned by Government vide Urban Development Deptt. Notification No. TPS-2496-2643-CR-300(a)97-UD-9, dated the 7th January 2000 and finally sanctioned by Government vide Notification No. TPS-2400-1628-CR-2000-UD-9, dated the 10th September 2001. As per Sanctioned Revised Development Plan of Nagpur city on dated 10/09/2001, the said land bearing Kh. No. 321, Mouza Nagpur, area 66,078.82 Sqmt. is shown as "Public-Semi Public Zone" and in Public-Semi public zone, Educational complex use is permissible. The said land is designated as "K.D.K Engineering College" in the said Development Plan of Nagpur city.
- **Land classification certificate (Mega/Metro/Urban/Rural)** :- The said land bearing Kh. No. 321, Mouza Nagpur, area 66,078.82 Sqmt. fall under Nagpur Urban area within Nagpur Municipal Corporation limit. The Nagpur Municipal Corporation is the 'Planning Authority' for the said area.
- **FSI as on date certificate** :- As per Sanctioned Unified Development Control and Promotions Regulations of dated 02/12/2020 (the regulations comes in-force from 03/12/2020), as per clause no. 6.3 Table 6G, the basic FSI of said plot is 1.10. As the said land is situated on 30.00 mt. wide Great Nag Road, and as per Table 6G of UDCPR-2020, the maximum building potential on plot including in situ FSI shall be 3.00.

Note:- This certificate is issue on request of your letter dated 10/05/2023

(Approved by Hon. Chairman, NIT, Nagpur)

Encl:- As above

Deputy Director Town Planning  
Nagpur Improvement Trust  
Nagpur

DEVENDRAPRA  
TAP BAIJNATH  
SINGH

Digitally signed by DEVENDRAPRA TAP BAIJNATH SINGH, DN: cn=DEVENDRAPRA TAP BAIJNATH SINGH, o=Nagpur Improvement Trust, email=devendrapra.tapbaijnath.singh@nitnagpur.org, c=IN, date=2023.05.10 11:32:02 +05'30'

Dr. Yuwara D. Kale  
M. S. Shaikya (Ayu)  
Principal  
B.K.

Bhauasheh Mulak Ayurved  
M...

UDCPR 2020

1. These Unified Development control and Promotion Regulations are sanctioned by the State Government under Section 37(1AA)(c) and Section 20(4) of the Maharashtra Regional & Town Planning Act, 1966 vide Notification No.TPS-1818/CR-236/18/DP&RP/Sec.37(1AA)(c) & Sec.20(4)/UD-13, Dated 02 December, 2020.
2. These Unified Development control and Promotion Regulations are published by the State Government under Section 20(3) of the Maharashtra Regional & Town Planning Act, 1966 vide Notice No.TPS-1818/CR-236/18/Sec.20(3)/UD-13, Dated 02 December, 2020.
3. Directives under Section 154 of the Maharashtra Regional & Town Planning Act, 1966 issued by the State Government vide Resolution No.TPS-1818/CR-236/18/Sec.20(3)/UD-13, Dated 02 December, 2020.
4. These Unified Development control and Promotion Regulations are published by the State Government under Section 37(1AA)(c) of the Maharashtra Regional & Town Planning Act, 1966 vide Notification No.TPS-1818/CR-236/18/Sec.37(1AA)/UD-13, Dated 02 December, 2020.
5. Directives under Section 154 of the Maharashtra Regional & Town Planning Act, 1966 issued by the State Government vide Resolution No.TPS-1818/CR-236/18/Sec.37(1AA)/UD-13, Dated 02 December, 2020.

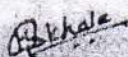
  
(Kishor Gokhale)  
Under Secretary  
Government of Maharashtra

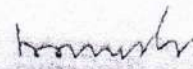
  
(N. R. Shende)  
Joint Secretary and Director of Town Planning  
Government of Maharashtra

DEVENDRA  
PRATAP  
BAIJNATH  
SINGH

Digitally signed by DEVENDRA PRATAP BAIJNATH SINGH  
DN: cn=DEVENDRA PRATAP BAIJNATH SINGH, o=GOVERNMENT OF MAHARASHTRA, ou=DEPARTMENT OF TOWN PLANNING, email=DEVENDRA.PRATAP.SINGH@maharashtra.gov.in, c=IN  
Date: 2020.12.03 11:00:00 +05'30'

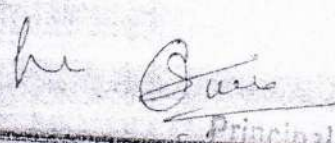
  
Principal

Bhau Sahab Malik Ayurved  
Mahavidyalaya, Nagpur

भाग एक (म.उ.वि.)---७४-२

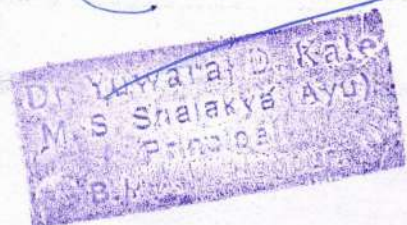
07 IV  
  
Dr. Yashraj D. Kale  
M.S. Shalaky (Ayu)  
Principal  
B.H.S. Mahavidyalaya, Nagpur

- 6.2.5 In case of group housing scheme where building abuts on internal road, the minimum 3m. set back from internal road or distance between two buildings whichever is more shall be provided. For Development plan road /Regional plan road or classified road or through road, passing through Group Housing Scheme, normal setback as prescribed in the regulations shall be provided.
- 6.2.6 Buildings Abutting Two or More Streets  
When a Building abuts two or more streets, the setbacks from the streets shall be such as if the building is fronting on each of such streets.
- 6.3 PERMISSIBLE FSI  
Permissible basic FSI, additional FSI on payment of premium, Permissible TDR Loading on a plot in non-congested area for Residential and Residential with mixed uses and other buildings in developable zones like residential, commercial, public-semi-public etc. shall be as given in Table 6 G below :-

DEVENDRAP  
RATAP  
BAIJNATH  
SINGH

Digitally signed by DEVENDRAP RATAP SINGH  
DN: cn=DEVENDRAP RATAP SINGH, o=Maharashtra State, email=DEVENDRAP.RATAP.SINGH@maharashtra.gov.in, c=IN  
Date: 2023.09.12 12:33:31 +05:30

07

Dr. Yuwara, D. Kale  
M. S. Shalakyā (Ayu)  
Principal  
B.M.A. Mahavidyalaya

*[Handwritten Signature]*  
Principal

Bhadracharya Ayurved  
Mahavidyalaya, Nagpur

Table 6G

Sr. No.	Road width in meters	Basic FSI	For all Municipal Corporations				For remaining authorities/areas		
			FSI on payment of premium	Maximum permissible TDR loading	Maximum building potential on plot including in-situ FSI	FSI on payment of premium	Maximum permissible TDR loading	Maximum building potential on plot including in-situ FSI	
1	2	3	4	5	6	7	8	9	
1	Below 9 m.	1.10	—	—	1.10	—	—	1.10	
2	9 m. and above but below 12 m.	1.10	0.50	0.40	2.00	0.30	0.30	1.70	
3	12 m. and above but below 15 m.	1.10	0.50	0.65	2.25	0.30	0.60	2.00	
4	15 m. and above but below 24 m.	1.10	0.50	0.90	2.50	0.30	0.70	2.10	
5	24 and above but below 30 m.	1.10	0.50	1.15	2.75	0.30	0.90	2.30	
6	30 and above	1.10	0.50	1.40	3.00	0.30	1.10	2.50	

C.S.

Dr. Yuwara D. Kale  
M.S. Shaikya (Ayu)  
B.M. Shaikya (Ayu)

Principal

Bhausahel Mata Ayurved  
Mahavidyalaya, Nagpur

DEVENDRAP  
RATAP  
BAIJNATH  
SINGH

Digitally signed by DEVENDRAP RATAP  
BAIJNATH SINGH  
DN: cn=DEVENDRAP RATAP BAIJNATH SINGH, o=DEVENDRAP RATAP BAIJNATH SINGH, email=DEVENDRAP.RATAP@BAIJNATHSINGH.COM, c=IN

B-8

BHAUSAHEB MULAK AYURVED MAHAVIDYALAY & MEDICAL SCIENCE AND RESEARCH HOSPITAL  
HOSPITAL AREA STATEMENT

RECEPTION AND REGISTRATION ZONE				
Area	Required Built-up Area (Sq. Mtr)	Available Carpet Area (Sq.Mtr)	Available Built-up Area (Sq.Mtr)	Available Built-Up Area (Sq.Ft)
Reception & Registration Zone		6.21	6.71	72.15
Waiting area	180	200.00	216.00	2324.16
Medical Record Room		41.36	44.67	480.68
Total	180	247.57	267.38	2877.00

Administrative Zone				
Area	Required Built-up Area (Sq. Mtr)	Available Carpet Area (Sq.Mtr)	Available Built-up Area (Sq.Mtr)	Available Built-Up Area (Sq.Ft)
Medical director	35	25.84	27.90	300.22
Medical superitendent	35			
PA TO MS	10	3.87	4.18	44.96
DMS	20	9.00	9.72	104.59
Administrator ,Online consultation,OPD incharge	55	4.46	4.81	51.79
Matron	20	5.46	5.90	63.45
Assistance Matron	15			
Office superIntendent	15	5.00	5.40	58.10
Accountant & other office staff	30	4.93	5.32	57.29
Waiting lounge for visitors	15	141.70	153.04	1646.67
RMO	30	33.77	36.47	392.46
Toilets	20	20.00	21.60	232.42
Pantry	5	5.95	6.42	69.12
Doctors lounge	30	15.56	16.81	180.85
Interns room	50	26.23	28.33	304.80
Staff Room	50	31.09	33.57	361.24
Meeting Hall	50	23.23	25.09	269.93
Store	75	19.40	20.95	225.43
Staff Room		31.09	33.57	361.24
Maintainence & Repair		67.09	72.46	779.64
Washing Area		11.24	12.14	130.59
TOTAL	560	484.89	523.68	5069.79

65

D. Yuvaraj Kal  
S. Shalakra (Ayu)  
Principal

*Etadole*  
Ar. Pooja M. Padole  
ARCHITECT  
CA/2013/58622  
N.I.T.L.S. NO.- 2600

OPD				
Area	Required Built-up Area (Sq. Mtr)	Avallable Carpet Area (Sq.Mtr)	Available Built-up Area (Sq.Mtr)	Available Built-Up Area (Sq.Ft)
Screening OPD	20	16.78	18.12	194.96
Atyayika chikitsa	30	38.14	41.19	443.17
Swasthya Vrutta	25	23.76	25.66	276.06
Kayachikitsa	25	23.06	24.90	267.94
Panchakarma	25	16.63	17.96	193.29
Shalya tantra	25	23.16	25.02	269.18
			0.00	
Shalakyatantra (Netra)	30	23.53	25.41	273.38
Shalakyatantra (Karna,nasa & Mukha,Dant)	30	17.90	19.33	208.02
Prasuti streeroga	25	22.54	24.35	261.97
Procedural rooms	20	23.20	25.06	269.60
Kaumarbhrutya	25	23.16	25.02	269.18
Vish chikitsa	25	22.35	24.14	259.71
Breast Feeding area		4.00	4.32	46.48
Waiting area,toilets area for wheel chair & stretcher,area for keeping housekeeping materials	200	200.00	216.00	2324.16
Drugs stores & dispensary	45	19.03	20.55	221.12
<b>TOTAL</b>	<b>550</b>	<b>497.23</b>	<b>537.01</b>	<b>5778.25</b>

IPD				
Medical IPD				
Area	Required Built-up Area (Sq. Mtr)	Avallable Carpet Area (Sq.Mtr)	Available Built-up Area (Sq.Mtr)	Available Built-Up Area (Sq.Ft)
Medicine IPD beds	360.00	503.10	543.35	5846.47
Casualty	30.00	38.14	41.19	443.17
Nursing counter & store ( one for every thirty beds)	40(20*2)	7.43	8.03	86.38
Nurse Room	40(20*2)	19.76	21.34	229.59
Ward procedural room	20.00	17.53	18.93	203.70
Clinical classrooms	90(45*2)	98.81	106.71	1148.20
Circulation area & corridors	30.00	179.30	193.64	2083.61
Toilets	400.00	400.00	432.00	4648.32

*Ar. Raja M. Padole*  
ARCHITECT  
CA/2013/58622  
N.I.T.L.S. NO.- 2600

62

Dr. Jyotiraj B. Kale  
(M.S. Shalakyā Ayu)  
B.I.A. No. 1007

Surgical IPD Beds				
surgery IPD beds	240.00	308.93	333.65	3590.03
Nursing counter	40(20*2)	18.63	20.12	216.48
Doctor Room	40(20*2)	9.68	10.45	112.43
Ward procedural room	20.00	41.12	44.41	477.81
Clinical classrooms	90(45*2)	64.59	69.76	750.63
Circulation area & corridors	30.00	30.00	32.40	348.62
Toilets	400.00	400.00	432.00	4648.32
pathya pathya-room		9.62	10.39	111.79
NICU		7.86	8.48	91.28
ICU		47.94	51.78	557.12
<b>TOTAL</b>	<b>1530.00</b>	<b>2202.43</b>	<b>2378.62</b>	<b>25593.98</b>

Panchakarma Procedural Management Zone				
Area	Required Built-up Area (Sq. Mtr)	Available Carpet Area (Sq.Mtr)	Available Built-up Area (Sq.Mtr)	Available Built-Up Area (Sq.Ft)
Reception & waiting	20	20.00	21.60	232.42
Consultation room	25	18.23	19.68	211.79
Preparation room, store,	50	24.73	26.71	287.39
Therapy room male	120 (30*4)	64.22	69.35	746.24
Therapy room female	120	39.08	42.21	454.19
Therapists room	30	17.08	18.44	198.44
<b>Total</b>	<b>245</b>	<b>183.33</b>	<b>198.00</b>	<b>2130.46</b>

SURGICAL THERAPY SECTION				
Area	Required Built-up Area (Sq. Mtr)	Available Carpet Area (Sq.Mtr)	Available Built-up Area (Sq.Mtr)	Available Built-Up Area (Sq.Ft)
Minor OT	100	17.72	19.14	205.97
Major OT	200	169.19	182.72	1966.07
Anushastra karma	50	23.67	25.56	275.04
Labour Room	50	21.76	23.50	252.81
Prasuti - Streeroga procedural room	30	13.01	14.05	151.13
Garbhasanskar	30	9.86	10.65	114.57
Kriyakalpa section	30	30.00	32.40	348.62
Physiotherapy section	100	57.15	61.72	664.09
Yoga section	50	223.65	241.54	2598.93
Netrarog O.T		52.78	57.01	613.38
<b>TOTAL</b>	<b>640</b>	<b>618.77</b>	<b>668.27</b>	<b>7190.61</b>

Dr. Yuvana D. Kale  
 M.S. Shalakra (Ayu)  
 Principal  
 B.M. ...

*A. P. D. Dole*  
 ARCHITECT  
 CA/2013/58622  
 N.I.T.L.S. NO.- 2600

DIGNOSTIC ZONE				
Area	Required Built-up Area (Sq. Mtr)	Available Carpet Area (Sq.Mtr)	Available Built-up Area (Sq.Mtr)	Available Built-Up Area (Sq.Ft)
Clinical Laboratory	175	71.55	77.27	831.47
Imaging section		30.10	32.51	349.79
Waiting Area & toilets		141.77	153.11	1647.47
Test report issue counter		7.39	7.98	85.87
<b>TOTAL</b>	175	250.81	270.87	2914.59
<b>Grand Total</b>	3880	4485.04	4843.84	52119.69

**College Area Statement  
Administrative Section**

Sr. No.	DEPARTMENT	Required Built-up Area (Sq. Mtr)	Available Carpet Area (Sq.Mtr)	Available Built-up Area (Sq.Mtr)	Available Built-Up Area (Sq.Ft)
1	Principal Cabin	100	65.27	77.67	835.74
2	PA to Principal	20	14.24	17.09	183.87
3	Visitors lounge	20	30.34	36.40	391.69
4	Office Superintendent	10	11.62	13.94	150.04
5	Clerical staff	110	14.07	16.88	181.67
	Clerical staff		14.24	17.09	183.87
6	Visitors lounge for office	20	39.00	46.80	503.57
7	Record Room (P)	40	41.00	49.20	529.39
8	Central Store (P)	80	71.08	85.29	917.73
9	Pantry	10	8.85	10.61	114.21
10	Toilets for office staff	20	4.06	4.88	52.47
11	College Council Meeting	130	106.00	127.20	1368.67
12	Vice Principal (P)	20	11.93	14.32	154.07
13	Central workshop & maintenance cell	50	67.07	72.44	779.41
	<b>Total</b>	<b>630</b>	<b>498.76</b>	<b>589.81</b>	<b>6346.39</b>

62

Dr. Yuwara D. Kale  
M.S. Shalakra (Ayu)  
B.M.S.

*Padole*  
Ar. Pooja M. Padole  
ARCHITECT  
CA/2013/58622  
N.I.T.L.S. NO. - 2600

Teaching Department

Sr. No.	DEPARTMENT	Required Built-up Area (Sq. Mtr)	Available Carpet Area (Sq.Mtr)	Available Built-up Area (Sq.Mtr)	Available Built-Up Area (Sq.Ft)
1	Samhita Siddhant & Sanskrit	180	165.00	198.00	2130.48
2	language Labortary	30	30.00	36.00	387.36
3	Rachana sharir	330	275.80	297.86	3205.02
4	Kriya sharir	305	220.61	238.26	2563.71
5	Dravyaguna	330	278.00	333.60	3589.54
6	Herbal garden	4000	4050.00	4050.00	43578.00
7	Rasshastra & B.K	330	244.00	263.52	2835.48
8	Quality testing Laboratory	300	180.00	216.00	2324.16
9	Rognidan	250	153.86	166.17	1788.00
10	Agadtantra	305	305.00	366.00	3938.16
11	Swasthvrutta & yoga	280	186.47	201.39	2166.93
12	Kayachikitsa	205	286.07	308.96	3324.36
13	Panchakarma	100	83.14	89.79	966.15
14	Shalyatantra	175	144.56	156.13	1679.95
15	Shalakyatantra	150	157.00	169.56	1824.47
16	Prasuti- Stree Roga	100	103.05	111.29	1197.52
17	Kaumarbhrutya	155	115.84	125.11	1346.15
18	Department of integrative health	50	16.00	17.28	185.93
19	Central Research Lab	150	65.48	70.72	760.93
	<b>Total</b>	<b>7725</b>	<b>7059.89</b>	<b>7415.64</b>	<b>79792.30</b>

Other units of college

*Padole*  
Ar. Pooja M. Padole  
 ARCHITECT  
 CA/2013/58622  
 N.I.T.L.S. NO.- 2600

62  
 Dr. Yuwara D. Kale  
 M.S. Shalaky (Ayu)  
 Prinsipa  
 B.M.

Sr. No.	DEPARTMENT	Required Built-up Area (Sq. Mtr)	Available Carpet Area (Sq.Mtr)	Available Built-up Area (Sq.Mtr)	Available Built-Up Area (Sq.Ft)
1	HRD Cell				
	Workshop	75	92.198	110.64	1190.46
	office , Storage , Circulation Area, Toilets		68	81.60	878.02
	Toilets (G)	50	21	25.20	271.15
	Toilets (L)		22	26.40	284.06
2	IT cell	50	16	19.20	206.59
3	Lecture Halls	750	166	199.20	2143.39
			160.44	192.53	2071.60
			160.44	192.53	2071.60
			160.44	192.53	2071.60
			166	199.20	2143.39
4	Multi- purpose hall for seminar or conference or examination or yoga & the like activities (Shared)	300	347.82	417.38	4491.05
5	Central Library	250	203	243.60	2621.14
6	Digital Library				0.00
	Wifi Campus	30	67	80.40	865.10
7	Language Laboratory	30	30	36.00	387.36
8	Research Innovation & Entrepreneurship development cell	30	17	20.40	219.50
9	Co-curricular & Extra curricular	100	106	127.20	1368.67
10	Boys Common Room	50	43.887	52.66	566.67
11	Girls Common Room	50	43.887	52.66	566.67
12	Common room for non- teaching staff (P)	40	42.22	50.66	545.14
13	Student Council room	30			
14	Student support career guidance & Placement cell, grievance redressal cell& Committee against sexual Harassment	25	44.81	53.77	578.59
15	Yogya clinical skill Laboratory	150	159	190.80	2053.01
16	Internal Quality assurance cell	40	40	48.00	516.48
17	NSS		16	19.20	206.59
	Total	2050.00	2193.14	2631.77	28317.85
TOTAL		10405.00	9751.79	10637.22	114456.54
TOTAL (HOSPITAL + ACADEMIC BLDG)		14285.00	14236.83	15481.06	166576.23

62

Dr. Yuvraj D. Kale  
 M.S. Shrikrishna (Ayu)  
 Principal  
 B.M. ...

Padole  
 A. Pooja M. Padole  
 ARCHITECT  
 CA/2013/58622  
 N.I.T.L.S. NO.- 2600

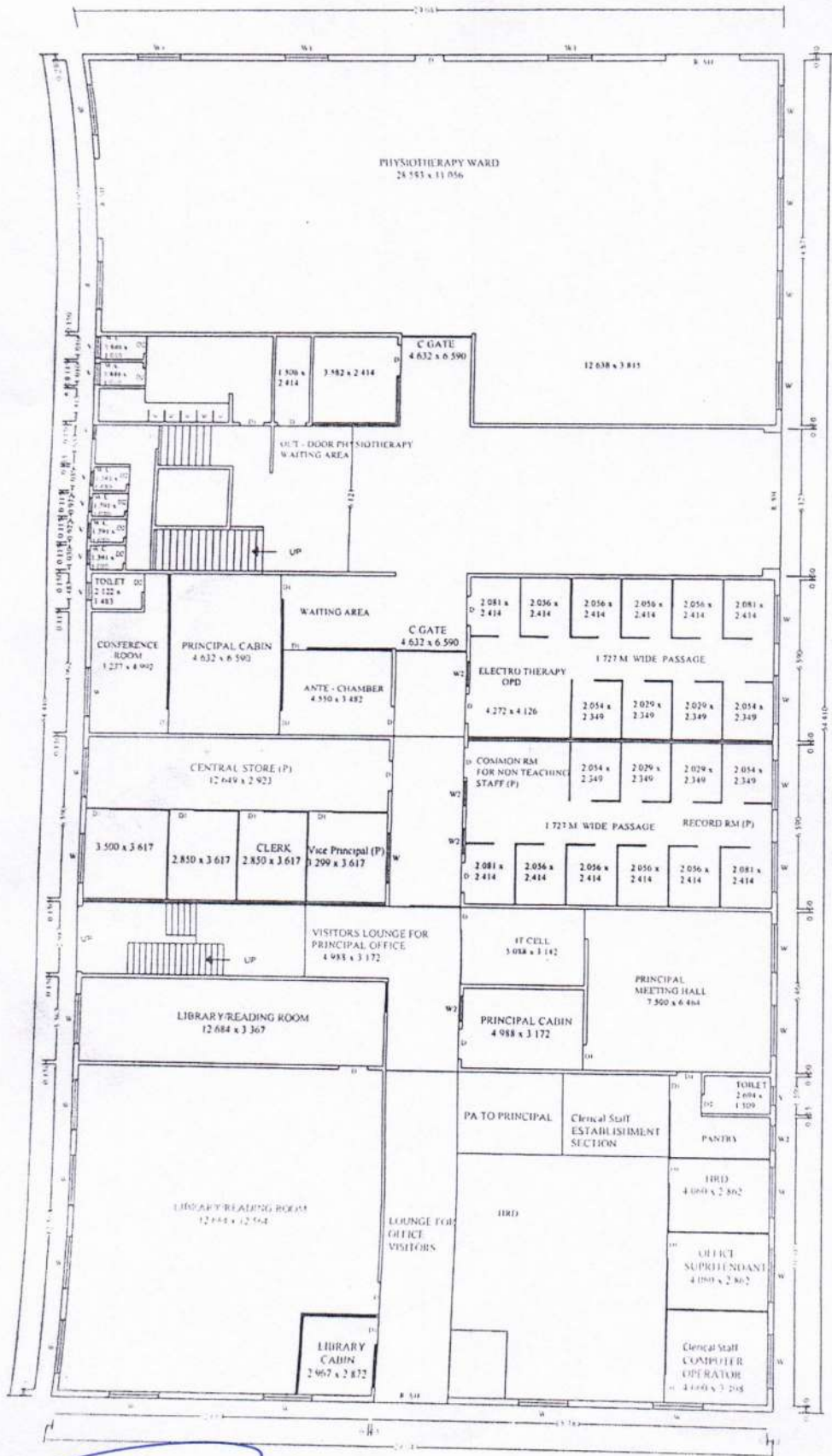

GROUND FLOOR PLAN  
SCALE 1 100

Dr. Yuwal Kale  
M.S. Shalakra (Ayu)  
Principal  
B.M.

*Handwritten signature*  
K. S. No. 2600

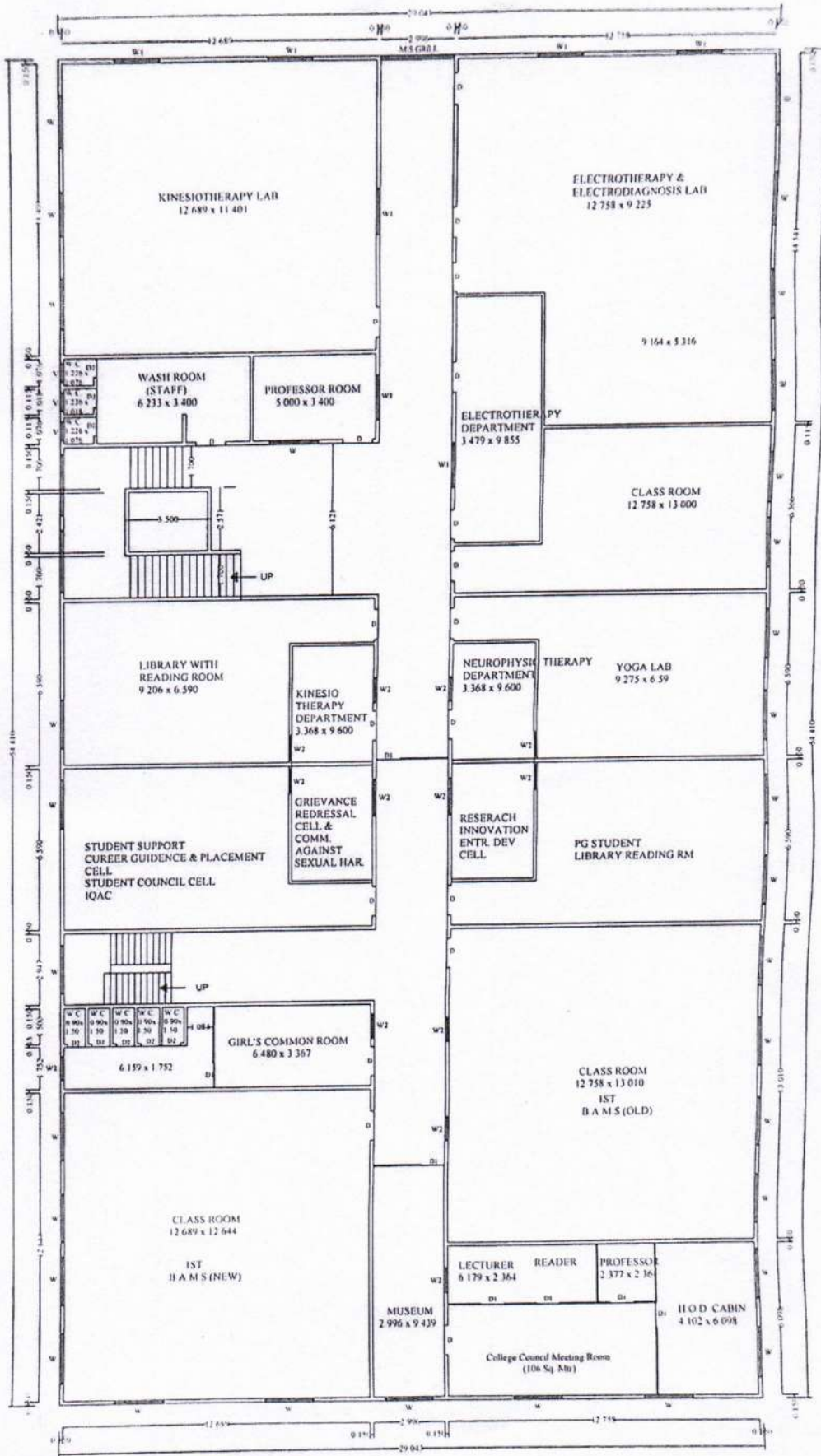

67  
**FIRST FLOOR PLAN**  
 SCALE 1:100

*Ar. Padole*  
**M. Padole**  
 ARCHITECT  
 CA/201/128622  
 N.T.S. NO. 2600

DR. YUVARA D. KALE  
 (M.S. Shalakra Ayu)  
 201202  
 B.M.

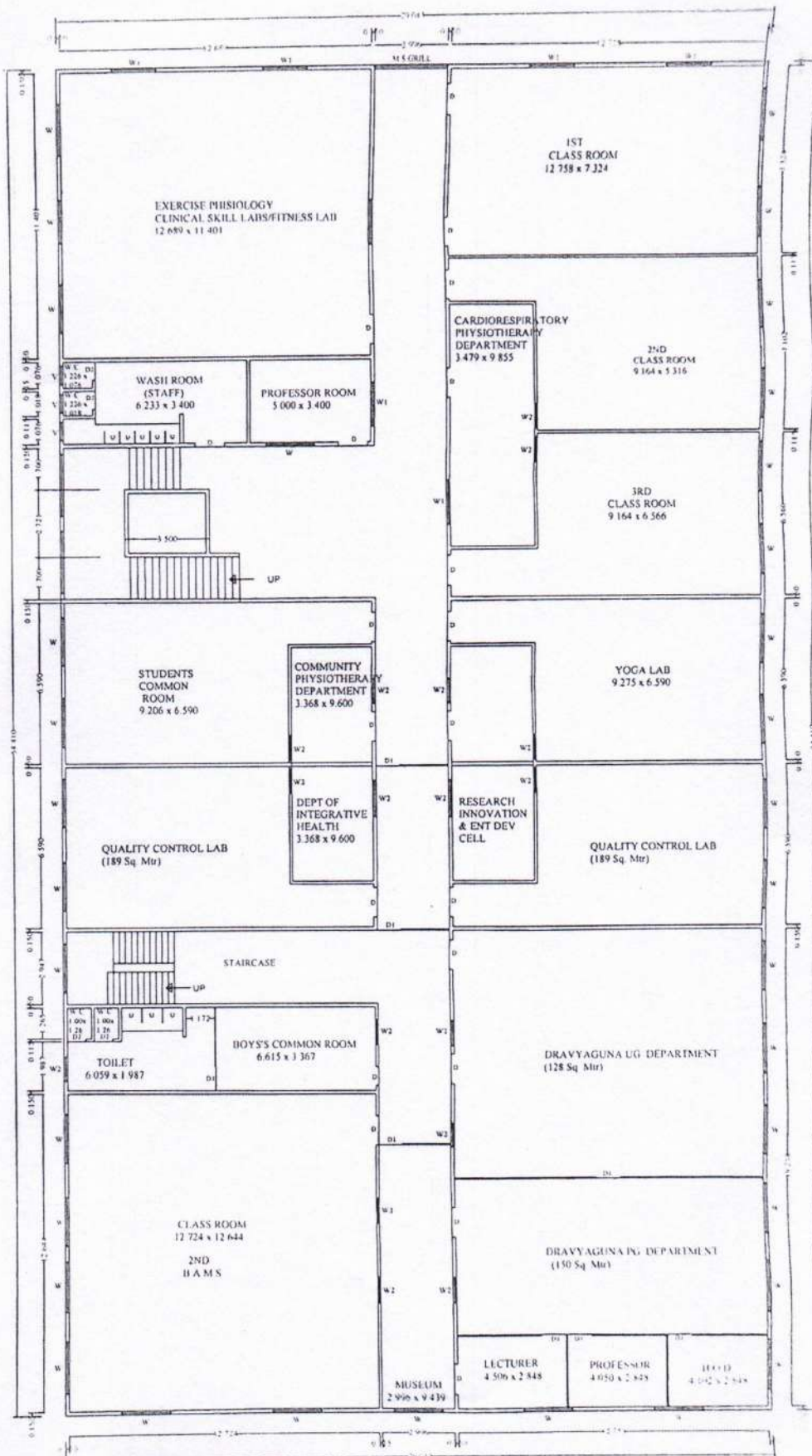

SECOND FLOOR PLAN

SCALE 1/100

*Aradhana M. Padole*  
ARCHITECT  
CAT. NO. 58622  
S.P.L.S. NO. 2600

Dr. Yuvatale Rale  
M.S. Shalakra (Ayu)  
B.M. 11/11/2022

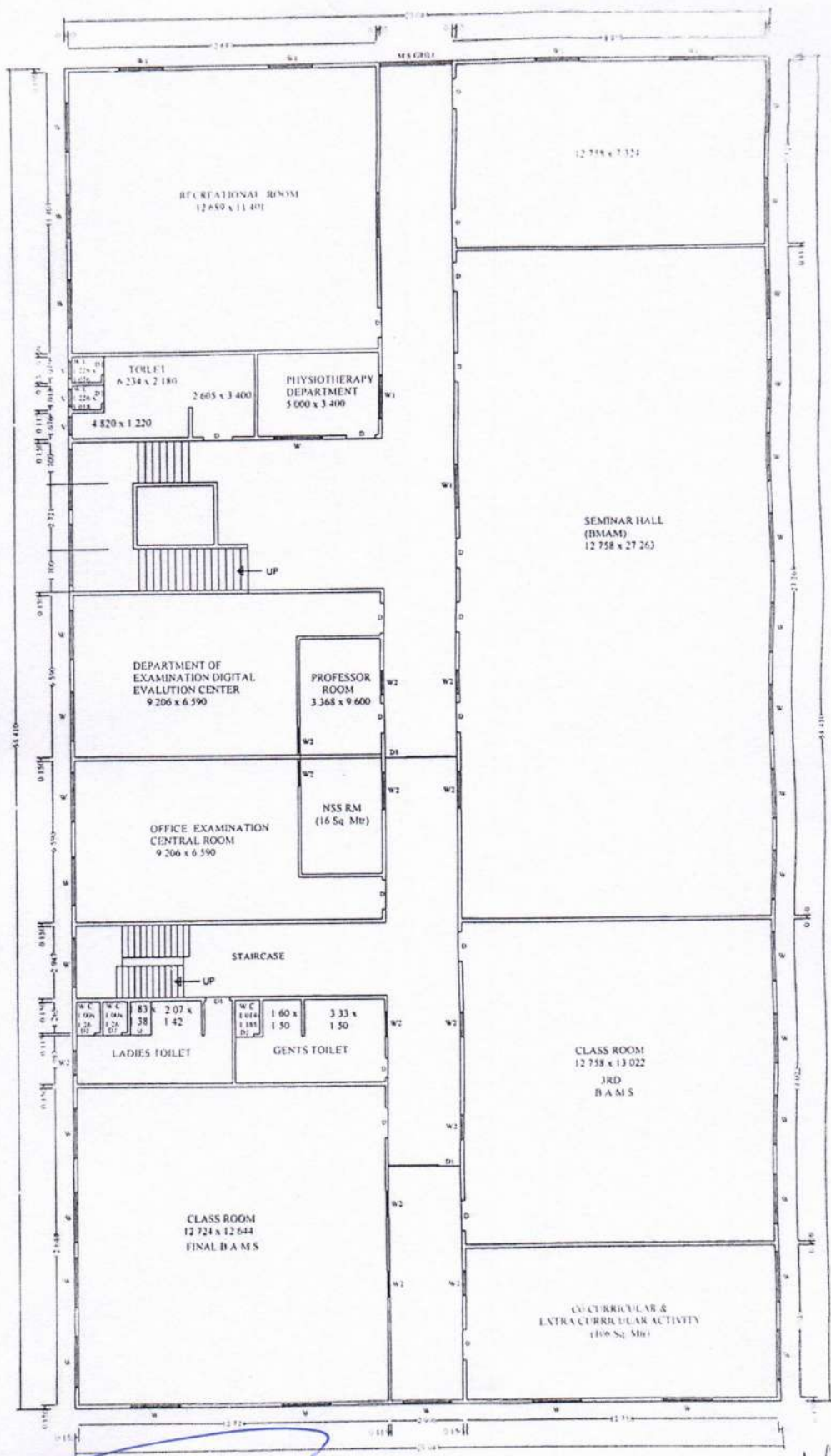

THIRD FLOOR PLAN  
SCALE 1 100

Architect: *Ar. J. S. Patil*  
 COLLECT  
 ON 2019 18622  
 N.P.S. NO 2600

DR. J. S. Patil  
 Mrs. Shalaky  
 Principal  
 B. K. ...







DR. YUVKATA D. KALE  
 M.S. SHAIKVA (AYU)  
 PUNE

Handwritten initials and a circled mark.

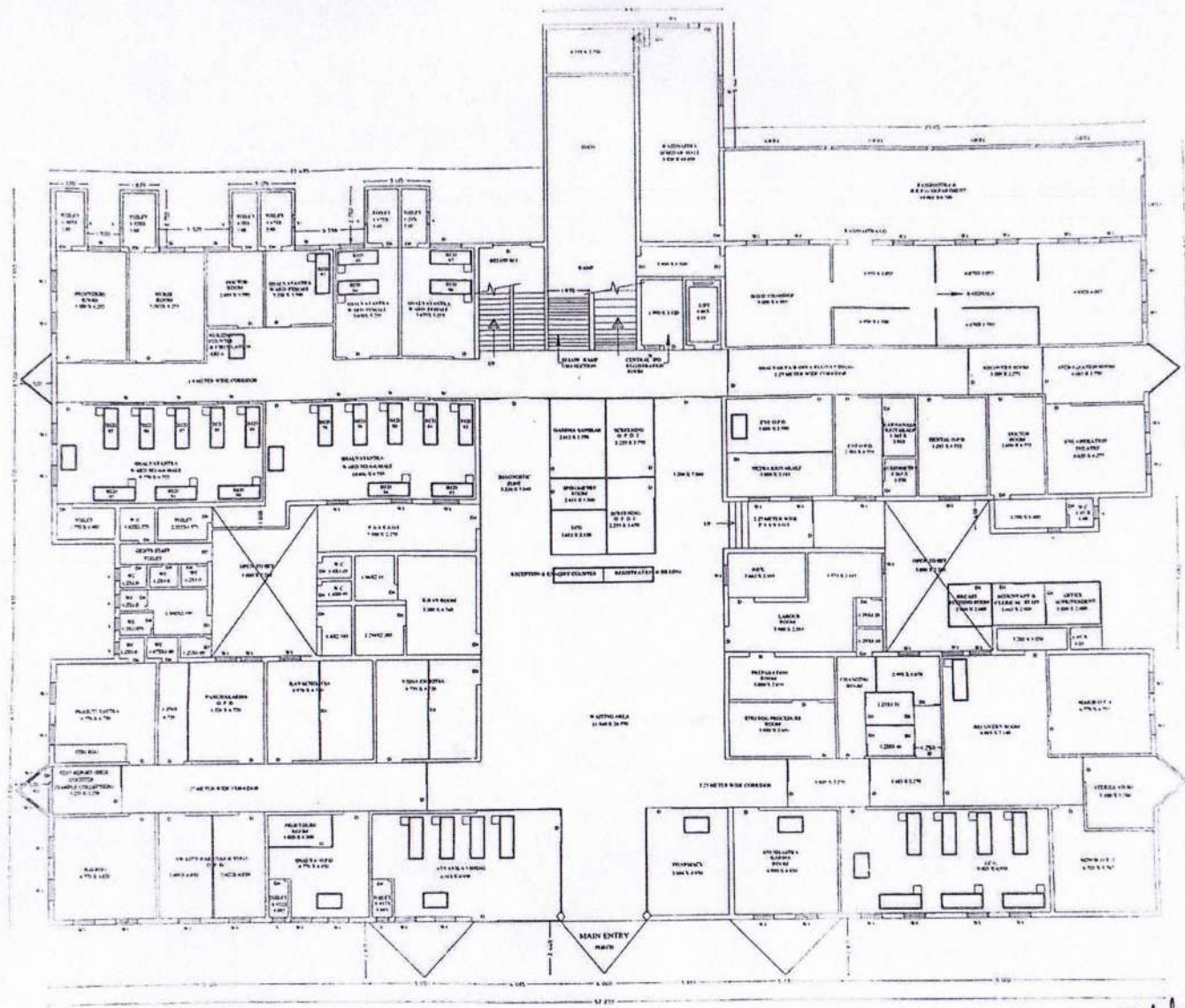

EXISTING GROUND FLOOR PLAN - FOR HOSPITAL BUILDING  
 SCALE: 1/100

*Atadole A. Padole*  
 ARCHITECT  
 CIVIL 17/08622  
 N.I.T.L.S. NO. - 2600

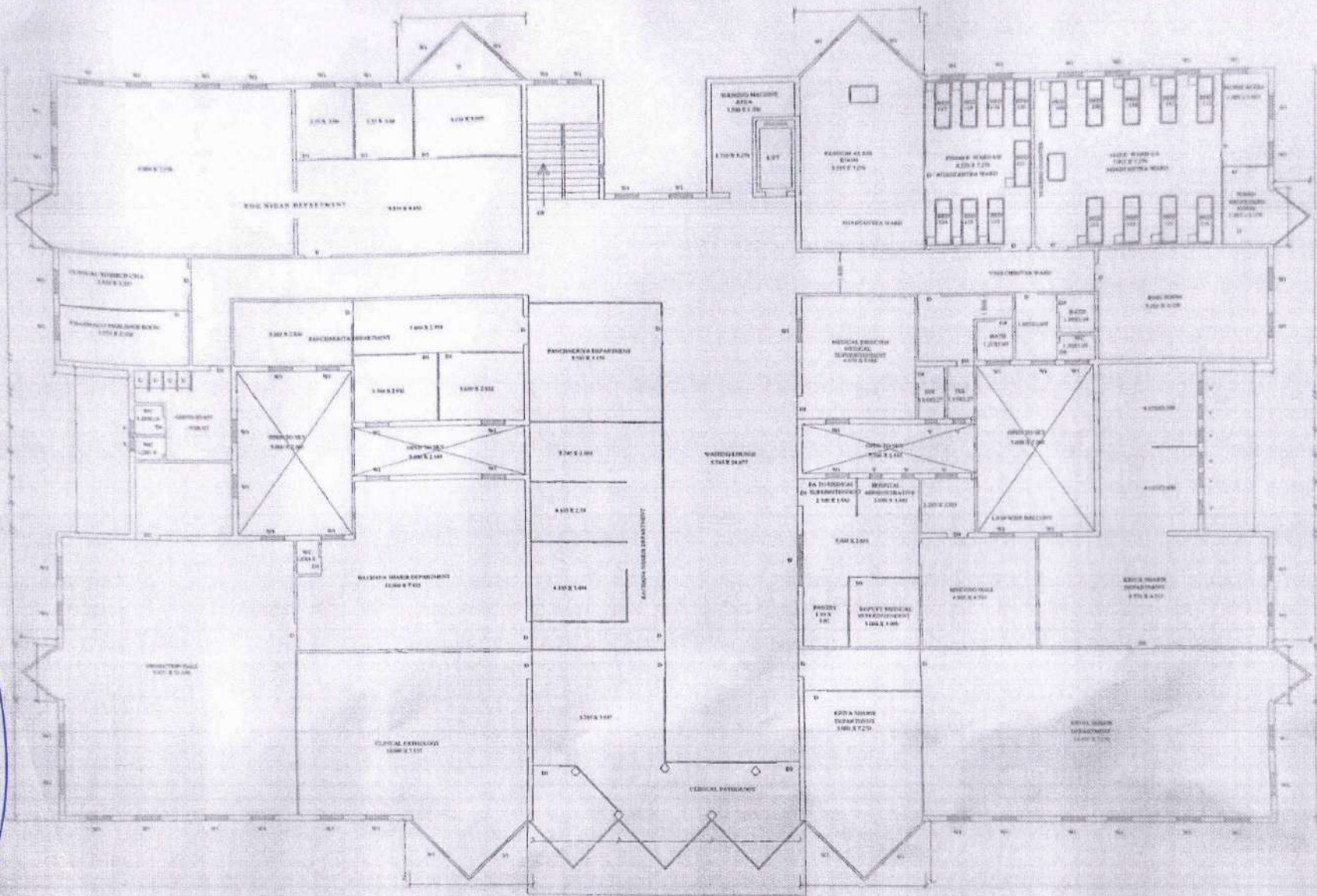

DR. JUYARAJ D. RAJ  
 M. S. Shaikya (AYU)  
 PRINCIPAL  
 B. M. ...  
 ...

OS

TYPICAL EXISTING SECOND FLOOR PLAN FOR HOSPITAL BUILDING

SCALE 1/100

*Ar. Ram M. Padole*  
 ARCHITECT  
 CA/2013/55623  
 N.I.T.S. NO. 2600

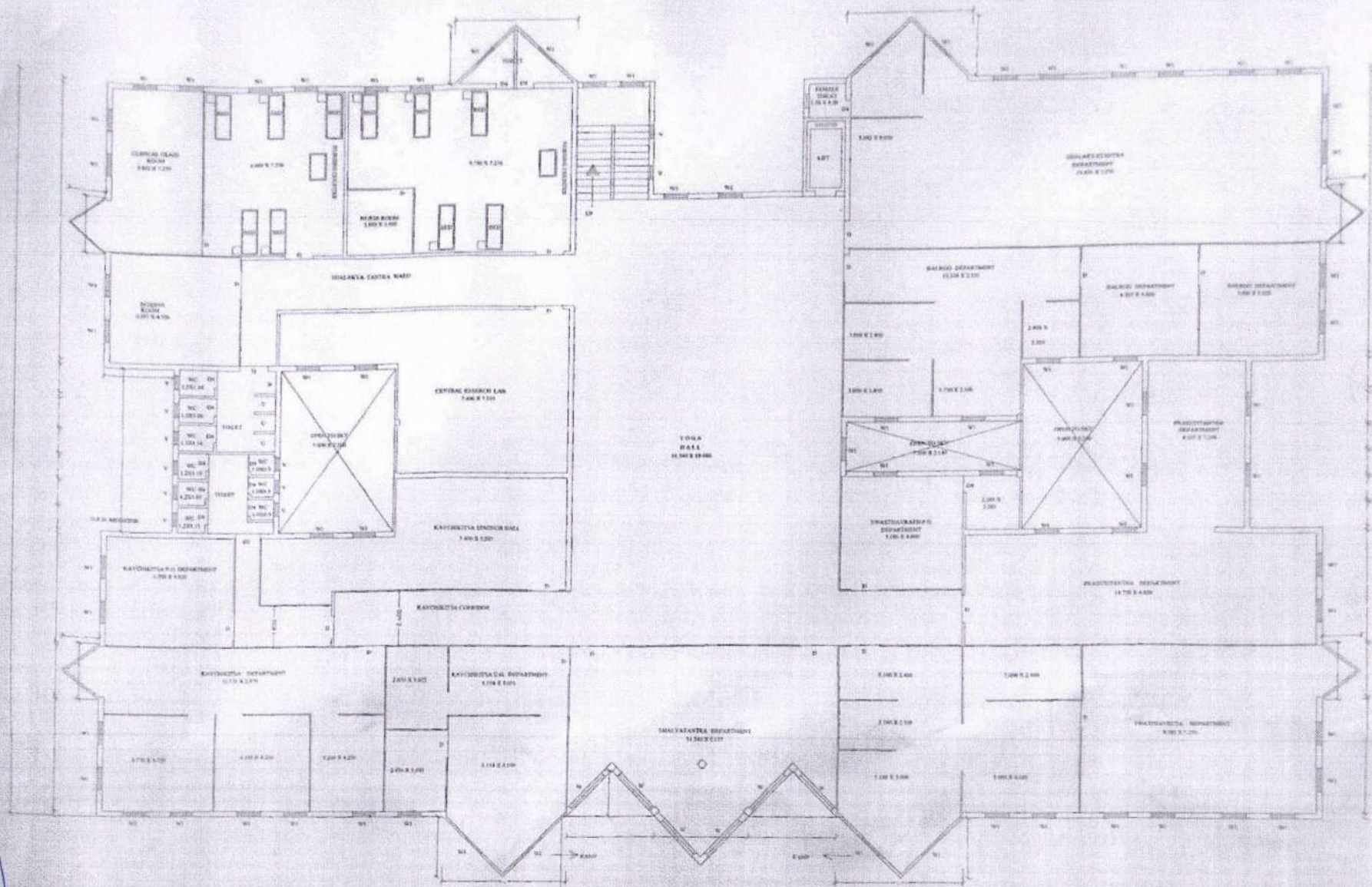

DR. JUYARAJ D. KHAN  
 M.S. SHAIKYE (AYU)  
 PRINCIPAL  
 B.M.



TYPICAL EXISTING THIRD FLOOR PLAN FOR HOSPITAL BUILDING

SCALE 1/100

*Ananta*  
**Ananta M. Padole**  
 ARCHITECT  
 CA/2013/58622  
 N.I.T.L.S. NO. - 2600

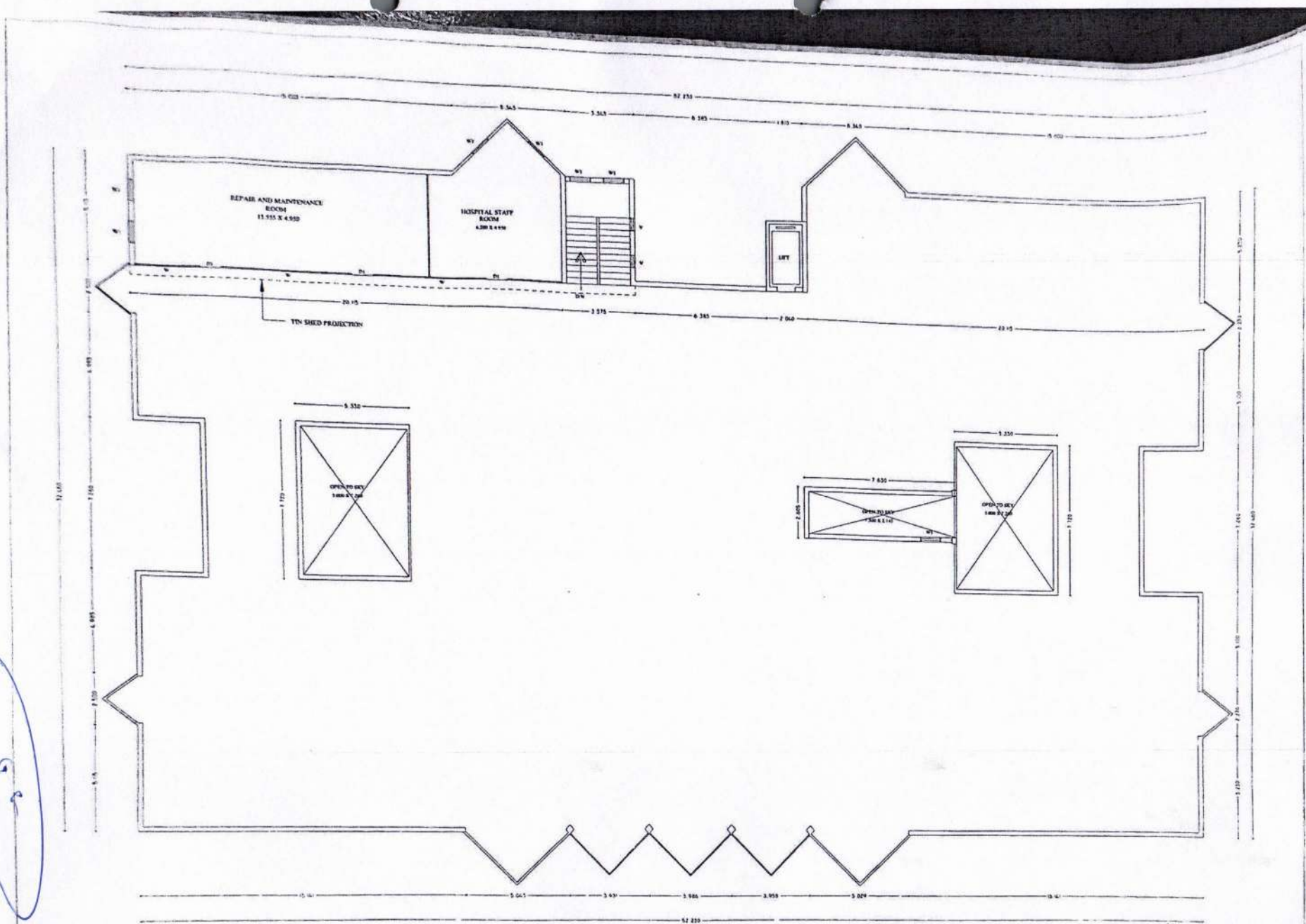

Dr. Jyotiraj D. Kale  
 M. S. Shalakyé (Ayu)  
 Principal



TYPICAL EXISTING FOURTH FLOOR (TERRACE) PLAN FOR HOSPITAL BUILDING  
 SCALE 1:100

*Pooja M. Padole*  
 ARCHITECT  
 CA/2013/58622  
 N.I.T.L.S. NO.- 2600

B-9

9

28

(50)

# NAGPUR IMPROVEMENT TRUST BUILDING PERMIT

No. BE / 212N.

Permit No. 94/15503/15435

Case No. 94/15435

Date 16-9-86.

Name of Applicant M/S Backward class youth relief Committee

Address Ichamla Rd. Nagpur

Site of proposed work Plot No. P.V. in kh. No. 321 Layout Nandanvan  
Kh. No. 321 Mouza Nagpur Wathoda Street Scheme

With Reference to your application dated 30-5-86  
Sanction is hereby given to construct in accordance with the sanctioned plans and the modifications here under so as not to contravene any of the Building Regulation/Development Control Rules.

Note- (1) Sanction is valid up to 12 months from the date of this permit No. construction can be carried out after this period, unless a start has been made within the period of sanction.

- (2) The building shall be used for the purpose prescribed in Development Control Rules.
- (3) No. departure from the sanctioned plan should be made without obtaining previous sanction of Trust if any construction is carried out in contravention of the sanctioned plan the Trust may require it to be demolished or altered in such manner as it may deem fit.
- (4) Inspection Notice have to be given to trust in prescribed form 'B'
  - i) on completion of setting out of the building, and
  - ii) on completion of plinth accompanied by stage completion certificate in form 'C'
 In either case construction of the building, shall not be proceeded, with unless the stage permits are obtained in time for each stage according to Building regulation of Development Control Rules Regulation No. 10.
- (5) The Building or part there of shall not be occupied or used until occupation certificate has been obtained from chairman as stated in Building Regulation No. 12 after giving Notice in form 'D' of such Completion as stated in Building Regulation No. 11 accompanied by Certificate in form 'B' signed by the supervisor, Party will be liable for prosecution for unauthorised occupation.
- (6) W.C. bath and washing place shall conform to requirement contained in Schedule 'A' attached to Building Regulation of the Trust.
- (7) Rain water shall be entirely excluded from the connecting sewer and separate arrangement for diverting rain water to road side storm drains shall be made. If any deviations are detected in this respect, the chairman's order for rectifying them shall be complied with.
- (8) All drainage work shall be got done through licenced plumber approved by Trust or Nagpur Municipal Corporation.

(P.T.O.)

*B*  
*Principal*  
Bhausahab Mulak Ayurved  
Mahavidyalaya Nagpur

*62*  
Dr. Yuvraj D. Kale  
M. B. Shalakyā (Ayu)  
Principal  
B. M. ...

- (9) W. C. bathroom and washing places shall not be used until proper connections are made as per schedule 'A' and completion Notice in form 'D' signed by licenced plumber mentioned in note (8) is given to Chairman and permission to use them is obtained.
- (10) During the course of constructions of building the sanctioned plan shall always be available at site for inspection by officials of trust.
- (11) Except as foresaid the permission is granted subject to compliance of Building Regulation for the time being in force and nothing herein contained shall be regarded as dispensing with such compliance except to the extent expressly specified therein.
- (12) This permission shall not be construed as affecting in any way the right of Government or Trust or the Municipal Corporation or any other authority, or any Private person or firm to the land upon which, permission has been sought to build or to any easement connected therewith.
- (13) The permit holder is not allowed to collect earth/materials from or throw earth materials over Trust land, without permission in writing from Chairman who may grant it on such terms and conditions as he may deem fit. If any material is stocked/earth dumped on Trust land without Trust's prior permission it shall be removed by Trust at the risk and cost of this permit holder and Trust shall not be responsible for any loss or damage caused to permit holder. No claim on this account shall be tenable against Trust.

(14) Sanctioned subject to condition of agreement executed by the party on \_\_\_\_\_  
 Subject to the condition that the party will plant  
 & grow in the vacant land of \_\_\_\_\_ shady  
 trees under provision of Tree Preservation Act 1915.  
 Enclosure :- One copy of Sanctioned & Plan  
 copy of agreement.

*W. Hanay*  
 Building Engineer  
 Nagpur Improvement Trust

No. BE/

Dated

Copy forwarded to

- 1) The Assessor, Nagpur Municipal Corporation for information. The Estimated cost of proposed building as per party's statement is Rs. \_\_\_\_\_
- 2) The Divisional Officer, \_\_\_\_\_ Scheme, Nagpur Improvement Trust for information.

With a copy of sanctioned ( enclosed herewith ) for record.

Encl For 2 :- One copy of agreement

Building Engineer  
 Nagpur Improvement Trust

*B. S. Mulak*  
 Principal  
 Bhausahab Mulak Ayurved  
 Mahavidyalaya, Nagpur

*cc*

Dr. Yuvraj D. Kale  
 M.S. Shalaky (Ayu)  
 Principal  
 B.M. ...

B-10



**NAGPUR MUNICIPAL CORPORATION, NAGPUR**  
**OFFICE OF THE ASSTT. COMMISSIONER**  
**NEHRU NAGAR ZONE NO. 5**

Letter No. - NMC/Occ. Certificate/A.C./Zone 5

Date :- 11/2/2017

**PART OCCUPANCY CERTIFICATE**  
**(Only for Building F with G+2 structure)**

To,

**Owner :- M/s CHAIRMAN, SMT. S. B. MULAK**  
**BACKWARD CLASS YOUTH RELIEF COMMITTEE**  
Kh. No. (AB)321, Mouza-Nagpur in Nandanvan layout near Nag road wathoda street scheme,  
Nagpur.  
**Architect, Licenses Engineer : P. S. BHAGADKAR**  
Plot no. 1 Gadage nagar Ramna Maroti nagar, Nagpur.  
N.M.C. Lic. (NMC/L-163)  
**Structural Engineer/Supervisor : AXIS CONSULTANT, SHRI. VINAYAK. D. VAIDYA**  
366, Shri Mahalaxmi Nagar, Nagpur 440 024.  
Lic No- AM099921-3

Sir,

The part development work/erection of building on plot No. 1128 House No. 1128/J, Prabhay No. 44, C.T.S No. 249, Mauza-Nagpur Completed under the supervision of Architect Shri P. S. Bhagadkar Licensed Architect Regd. no. NMC/L-163 may be occupied on the following conditions. This certificate valid only for building no. F in the premises. Occupation Certificate is for building constructed as per sanctioned building plan no. 677/BP/Nagpur/TP/NMC/1124 dt. 27/12/2010

1. Part Occupation Certificate is for building constructed as per sanctioned building plan no. 677/BP/Nagpur/TP/NMC/1124 dt. 27/12/2010
2. Parking area as per sanctioned building plan shall be strictly used for parking purpose only as well as the space on each and every floor shall be used for the purpose for which it is sanctioned.
3. This certificate does not approved any deviation, from sanctioned plan after date of issuing of this Part Occupancy Certificate. If any unauthorized construction is done action shall be taken as per the provisions of MRTTP Act, 1966 and MMC Act.
4. All the conditions in the Building permit No. 677/BP/Nagpur/TP/NMC/1124 dt. 27/12.2010 shall be binding on the party. Also the condition mentioned in the NOC No. GA/1154//FB dt. 04.11.2010, issued by the Fire Brigade Deptt. Of NMC shall be strictly complied with.
5. Structural stability is the sole responsibility of owner/Builder.
6. Owner should maintain rain water Harvesting system and solar heating system.
7. The party shall plant & grow 7 shady trees in vacant land of plot.
8. All the relevant provisions of Development Control Regulations for Nagpur City shall be binding on the party.
9. Utmost care shall be taken while construction work of the remaining portion of the building premises. If any untoward incident occurs, owner shall be fully responsible.
10. This part occupancy certificate is valid only the applicant obtains the compliance certificate from the Fire and Emergency Service Department of N.M.C. regarding the Fire fighting Arrangement.

Encl :- 1) One set of Certified Completion plans is returned herewith. (For F building only)

*M. Anil* 325  
Assistant Commissioner  
Nehru Nagar Zone No. 5  
N.M.C. Nagpur

*Ca*  
Dr. Yawara D. Kale  
M. S. Shalakyā (Ayu)  
Principal  
B.M. Ayurved Hospital

*h*  
*Atul*  
Principal  
Bhausaheb Mulak Ayurved  
Mahavidyalaya, Nagpur

Girl's Hostel



NAGPUR MUNICIPAL CORPORATION, NAGPUR  
OFFICE OF THE ASSTT. COMMISSIONER  
NEHRU NAGAR ZONE NO. 5

OW/1404/AC-5  
Letter No. - NMC/Occ. Certificate/A.C./Zone 5

Date :- 13/1/15

PART OCCUPANCY CERTIFICATE

(Only for Building L with G+3 structure)

To,

Owner :- M/s CHAIRMAN, SHRI. S. B. MULAK

BACKWARD CLASS YOUTH RELIEF COMMITTEE

Kh. No. (AB)321, Mouza-Nagpur in Nandanvan layout near Nag road wathoda street scheme,  
Nagpur

Architect, Licenses Engineer : P. S. BHAGADKAR

Plot no. 1 Gadage nagar Ramna Marol nagar, Nagpur.

Structural Engineer/Supervisor : SHIR. VIKRANT VAIDYA

"Mandakini" plot no. 131, old Subhedeer layout, Nagpur.

N.M.C. Lic. (NMC/L-498)

Sir,

The part development work/erection of building on plot No. 1128 House No 1128/L, Prabhag No 44, C.T.S No. 249, Mauza-Nagpur Completed under the supervision of Architect Shri P. S. Bhagadkar Lincensed Architect Regd no. NMC/L-163 may be occupied on the following conditions. This certificate valid only for building no. L

1. Occupation Certificate is for building constructed as per sanctioned building plan no. 677/BP/Nagpur/TP/NMC/1124 dt. 27/12/2010
2. Parking area as per sanctioned building plan shall be strictly used for parking purpose only as well as the space on each and every floor shall be used for the purpose for which it is sanctioned.
3. This certificate does not approved any deviation, from sanctioned plan after date of issuing of this Occupancy Certificate. If any unauthorized construction is done action shall be taken as per the provisions of MRTP Act, 1986 and MMC Act.
4. All the conditions in the Building permit No. 677/BP/Nagpur/TP/NMC/1124 dt. 27/12.2010 shall be binding on the party. Also the condition mentioned in the NOC No. GA/1154/WFB dt. 04.11.2010, issued by the Fire Brigade Deptt. Of NMC shall be strictly complied with.
5. Structural stability is the sole responsibility of owner/Builder.
6. Owner should maintain rain water Harvesting system and solar heating system.
7. The party shall plant & grow 7 shady trees in vacant land of plot.
8. All the relevant provisions of Development Control Regulations for Nagpur City shall be binding on the party.
9. Utmost care shall be taken while construction work of the remaining portion of the building premises. If any untoward incident occurs, owner shall be fully responsible.
10. This part occupancy certificate is valid only after the applicant obtains the compliance certificate from the Fire and Emergency Service Department of N.M.C. regarding the Fire fighting Arrangement.

Encl :- 1) One set of Certified Completion plans is returned herewith (For L building only)

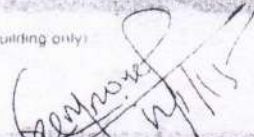
  
Assistant Commissioner  
Nehru Nagar Zone No. 5  
N.M.C. Nagpur

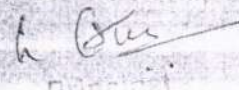
  
Principal  
Bhausahab Malak Ayurved  
Mahavidyalaya, Nagpur

  
Dr. Yuwara D. Kale  
M.S. Shalakyā (Ayu)  
Principal  
B.M.A. Mahavidyalaya



# BACKWARD CLASS YOUTH RELIEF COMMITTEE

140, "Rajvilla", Khamla Road, Nagpur - 440025.

Registration No. Maharashtra  
152 / 74 (N.)

Ph.No. : (0712) 2283543, 2283815, Fax : (0712) 2713658

Smt. Sumanmala B. Mulak  
Chairman

Shri. Rajendra B. Mulak  
Secretary

Shri. Yashraj R. Mulak  
Treasurer

Ref. No.: BCYRC/Work order/78/2019

Date : 24/07/2019

## WORK ORDER CUM AGREEMENT

To,  
Krishna Gangaa Enviro System Pvt Ltd.  
LGF-3, Shree Ganesh Heights, Opp Arun Automobiles,  
Khamla Square, Nagpur

Subject: Work Order for your firm for Execution of "Sewage Treatment Plant"  
Reference: your quotation dt. 30 Oct, 2018 and subsequent Negotiation Meeting

Dear Sir,

With reference to above cited matter our management is pleased to place Work Order for your firm for Execution "Sewage Treatment Plant" at BMAM Premises, KDKCE Campus, Great Nag Road, Nandanvan, Nagpur-440009

### Form of Agreement

#### A) Description of Work Allotted, Approved Cost, Execution Time and Payment Terms

Execution of "Sewage Treatment Plant- 20 m<sup>3</sup>/D" at BMAM Premises, KDKCE Campus, Great Nag Road, Nandanvan, Nagpur-440009

Approved Cost of Plant: Rs. 854024 (in words: Rupees Two Lacs Only) Inclusive of all taxes and Transport

Execution Time: Within 60 Days from Work order

Payment Terms: As per Quotation

#### B) Other Terms & Condition

- The project for which the Work is being performed is the KDK College of Engineering campus situated at Nagpur.
- Agency will provide full time Supervision at the site to ensure that the works are being executed in general accordance with the specifications and drawings.
- Agency will take the safety of persons involved in the work and the surrounding public.
- Items of work and specifications shall be as per the schedule A.
- Scope of work includes execution of items complete in all respects. The scope includes labour, material, other resources necessary, guarantee of work, etc. & taxes as applicable. Rates are for completed items of work
- Agency will take efforts for Issuing NOC from Government Authorities
- This letter & entire Documents form a part of contract and the same should be signed by you again for our records.

Regards,

Secretary  
BCYRC

Dr. Yuvaraj D. Kale  
M.S. Shalakyá Ayu  
Principal  
B.M.

Bhausaheb  
Mansingh

B-11

K<sub>G</sub>

## KRISHNA GANGAA ENVIRO SYSTEM PVT LTD

Plot No 1 Navnath Society, Budhwar Bazar Road, Near Jayanthi Mansion 2,  
Parallel to Railway Line, Narendra Nagar Extension, Nagpur - 440015

7770085947 / 8605024327

kgcon\_nagpur @ yahoo.com, acc.kges @ gmail.com, accounts @kgespltd.co.in  
[www.kgespltd.co.in](http://www.kgespltd.co.in)

Dt 18.10.21

To  
Backward Class Youth Relief Committee,  
Khamla Road, Nagpur -25

Kind Atten : Satone Sir

Sub : STP and ETP at BMAM Premises , KDKCE Campus, Nandanwan , Nagpur -- 440009

Dear Sir,

Referring to the above work of STP and ETP , the work is in progress and we will require another one month to complete the same. This is for your kind information and Record.

Regards

For Krishna Gangaa Enviro System Pvt Ltd

-sd/-

(Dr. Gajendr Sundar)

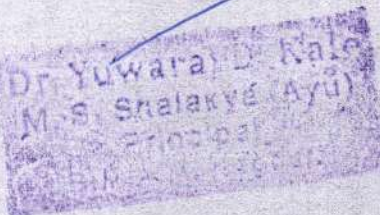

# BACKWARD CLASS YOUTH RELIEF COMMITTEE

140, "Rajvilla", Khamla Road, Nagpur - 440025.

Registration No. Maharashtra  
152 / 74 (N.)

Ph.No. : (0712) 2283543, 2283815, Fax : (0712) 2713658

**Smt. Sumanmala B. Mulak**  
Chairman

**Shri. Rajendra B. Mulak**  
Secretary

**Shri. Yashraj R. Mulak**  
Treasurer

BCYRC/

Date: 13/06/19

## WORK ORDER CUM AGREEMENT

To,

Krishna Gangaa Enviro System Pvt Ltd.  
LGF-3, Shree Ganesh Heights, Opp. Arun Automobiles,  
Khamla Square, Nagpur

Subject: Work Order for your firm for Execution of "Sewage Treatment Plant"

Reference: your quotation dt. 30 Oct, 2018 and subsequent Negotiation Meeting

Dear Sir,

With reference to above cited matter our management is pleased to place Work Order for your firm for Execution "Sewage Treatment Plant" at BMAM Premises, KDKCE Campus, Great Nag Road, Nandanvan, Nagpur-440009

### Form of Agreement

#### A) Description of Work Allotted, Approved Cost, Execution Time and Payment Terms

Execution of "Sewage Treatment Plant- 20 m<sup>3</sup>/D" at BMAM Premises, KDKCE Campus, Great Nag Road, Nandanvan, Nagpur-440009

Approved Cost of Plant: Rs. 854024 (In words: Rupees Two Lacs Only) Inclusive of all taxes and Transport

Execution Time: Within 120 Days from Work order

Payment Terms: As per Quotation

#### B) Other Terms & Condition

- The project for which the Work is being performed is the KDK College of Engineering campus situated at Nagpur.
- Agency will provide full time Supervision at the site to ensure that the works are being executed in general accordance with the specifications and drawings.
- Agency will take the safety of persons involved in the work and the surrounding public.
- Items of work and specifications shall be as per the schedule A.
- Scope of work includes execution of items complete in all respects. The scope includes labour, material, other resources necessary, guarantee of work, etc. & taxes as applicable. Rates are for completed items of work.
- Agency will take efforts for Issuing NOC from Government Authorities
- This letter & entire Documents form a part of contract and the same should be signed by you again for our records.

Regards,

  
Secretary  
BCYRC



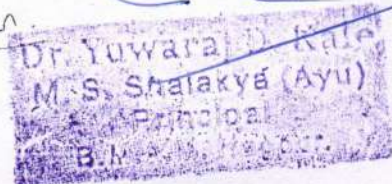



## KRISHNA GANGAA ENVIRO SYSTEM PVT LTD

LGF-3, SHRI GANESH HEIGHTS OPP. ARUN AUTOMOLIES  
KHAMLA SQUARE, NAGPUR-440015  
0712- 2248300 / 9422106527 /8605024327  
kgcon\_nagpur @ yahoo.com, info@kgespltd.com

### 3.0 SCOPE OF CLIENT

- Electricity : 3 Phase connection near proposed ETP site with earthing pit
- Civil Works as per KGES Design

S.No	Item	Eff. Volume	Remark
1	Raw Collection Tank	@ 12 cum	RCC
2	Chlorine Contact tank	@ 5 cum	RCC
3	Treated Water Tank	@ 8 cum	RCC
4	Sludge Drying Bed *	1.0 m x 1.0 m – 2 nos	Brick Work as per site conditions

Cost of Civil Works at actual by client

*Spohagadkar*

65  
Dr. Yuwaraj D. Kale  
Mr. S. Shalakra (Ayu)  
Principal  
B.A. ...

**K<sub>G</sub>****KRISHNA GANGAA ENVIRO SYSTEM PVT LTD**

LGF-3, SHRI GANESH HEIGHTS OPP. ARUN AUTOMOLIES

KHAMLA SQUARE, NAGPUR-440015

0712- 2248300 / 9422106527 /8605024327

kgcon\_nagpur@yahoo.com, info@kgespltd.com

**4.0 SCOPE OF KRISHNA GANGAA ENVIRO SYSTEM**

S.No.	Item	Specification	Qty.	Make
1.	Raw wastewater feed pump	2.0 cum/hr @ 9.0m head with CI Impeller, solid handling pump	1 w + 1 s	Kirloskar/Crompton
2	MMBR Media	Recycled PP Media	Suitable Qty	Marvelous /Equivalent
3	Lamella Clarifier Media	UV stabilized	Suitable Qty	Marvelous/ Equivalent
4	MMBR Tank	5 mm thick MS Epoxy Tank	1 No	Fabricated
5	Lamella Clarifier Tank	5 mm thick MS Epoxy Tank	1 No	Fabricated
6	Blower with diffuser for aeration Motor  Or Submersible Aerator	Twin Lobe blower	1 w + 1 s	Blower – IR / Airvak Diffuser – EPDM Fine Bubble and coarse bubble Diffuser
		3 Phase motor of suitable HP	1 w + 1 s	Motor – Kirloskar/Greaves
7	Piping within battery limit (raw and treated wastewater piping not included)	UPVC & PVC with suitable valves	1 Job	Prince / Jain / Equivalent
8	Electrical panel with internal aluminum cabling	Non - compartmentalized Powder coated Panel	1 Job	Fabricated with L&T / Siemens Internals/CNS
9	Bleaching Powder Dosing Tank	HDPE	1 No	Reputed
10.	MGF Feed Pump	2.0 cum/hr @ 25.0m head with CI Impeller, solid handling pump	1 w + 1 s	Kirloskar/Crompton
11	MGF	Graded Filter with Sand	1 No	Reputed
12	ACF	Graded Filter with Carbon	1 No	Reputed

*S. Prabhakar*

(STP- 20 m<sup>3</sup>/d)

3

30.10.2018 (Fabricated)

Dr. Yuwara D. Kale  
M.S. Shalaxya (Ayu)  
Principal  
B.H.

**K<sub>G</sub>****KRISHNA GANGAA ENVIRO SYSTEM PVT LTD**LGF-3, SHRI GANESH HEIGHTS OPP. ARUN AUTOMOLIES  
KHAMLA SQUARE, NAGPUR-440015

0712- 2248300 / 9422106527 / 8605024327

kgcon\_nagpur@yahoo.com, info@kgespltd.com

**6.0 COST BREAK-UP**

S.No.	Item	Amount
1.	Supply, erection and commissioning of Items 1 to 12 Listed in Table above	Rs 7,44,000=00 + Tax + Transportation
2.	Taxes relating to work	18 % GST Extra
3.	Transport from Nagpur to site , unloading , shifting to location	At actuals
4.	Civil Works	At actuals by client

**7. TERMS & CONDITIONS**

1] Client to provide water & electricity free of cost during construction & erection of plant at site.

**2] PAYMENT TERMS**

- 30 % Advance  
25 % On submission of functional designs  
40 % Against proforma invoice before material dispatch  
05 % on commissioning of the plant within 7 days

3] All warrantee of material would be 12months from date of supply for manufacturing defects only

**4] Disputes Redressal**

The agreement/work order / supply order would be subject all terms and conditions of Arbitration Act with Arbitrator being appointed as per mutual consent of both the parties. Further all legal matter would be subject to Jurisdiction of Nagpur Court

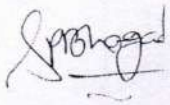
(STP- 20 m<sup>3</sup>/d)

Dr. Yuwara D. Kale  
M. S. Shalakyā (Ayu)  
Principal  
B.M.A. Nagpur

30.10.2018 (Fabricated)

**K<sub>G</sub>**

**KRISHNA GANGAA ENVIRO SYSTEM PVT LTD**

LGF-3, SHRI GANESH HEIGHTS OPP. ARUN AUTOMOLIES  
KHAMLA SQUARE, NAGPUR-440015  
0712- 2248300 / 9422106527 /8605024327  
kgcon\_nagpur@yahoo.com, info@kgespltd.com

5] Force Majeure Conditions

Should the delivery be delayed or prevented due to acts of god, fire, earthquake, civil commotion, government ordinance, import/export regulation, strikes, lockout, trade disputes, and difficulties in obtaining material, power shortage, accidents or any other causes which are beyond the control of supplier, suitable extension in delivery date shall be granted by the customer.

6] Escalation: If the material is not lifted within 4 months of order with advance, escalation as per prevalent market rate would be applicable.

7] No flow Condition: If within 1.5 months of erection, plant cannot be commissioned due to non availability of inflow, client to take dry test and release the payment,

Yours Truly,  
For Krishna Gangaa Enviro System Pvt Ltd  
-sd-  
[Dr Gajendr Sundar]

CS  
Dr. Yuwara D. Rale  
M. S. Shalakyá (Ayu)  
Principal  
B.M. ...

*Prabhakar*

**KG**

**KRISHNA GANGAA ENVIRO SYSTEM PVT LTD**

LGF-3, SHRI GANESH HEIGHTS OPP. ARUN AUTOMOLIES  
KHAMLA SQUARE, NAGPUR-440015  
0712- 2248300 / 9422106527 /8605024327  
kgcon\_nagpur@yahoo.com, info@kgespltd.com

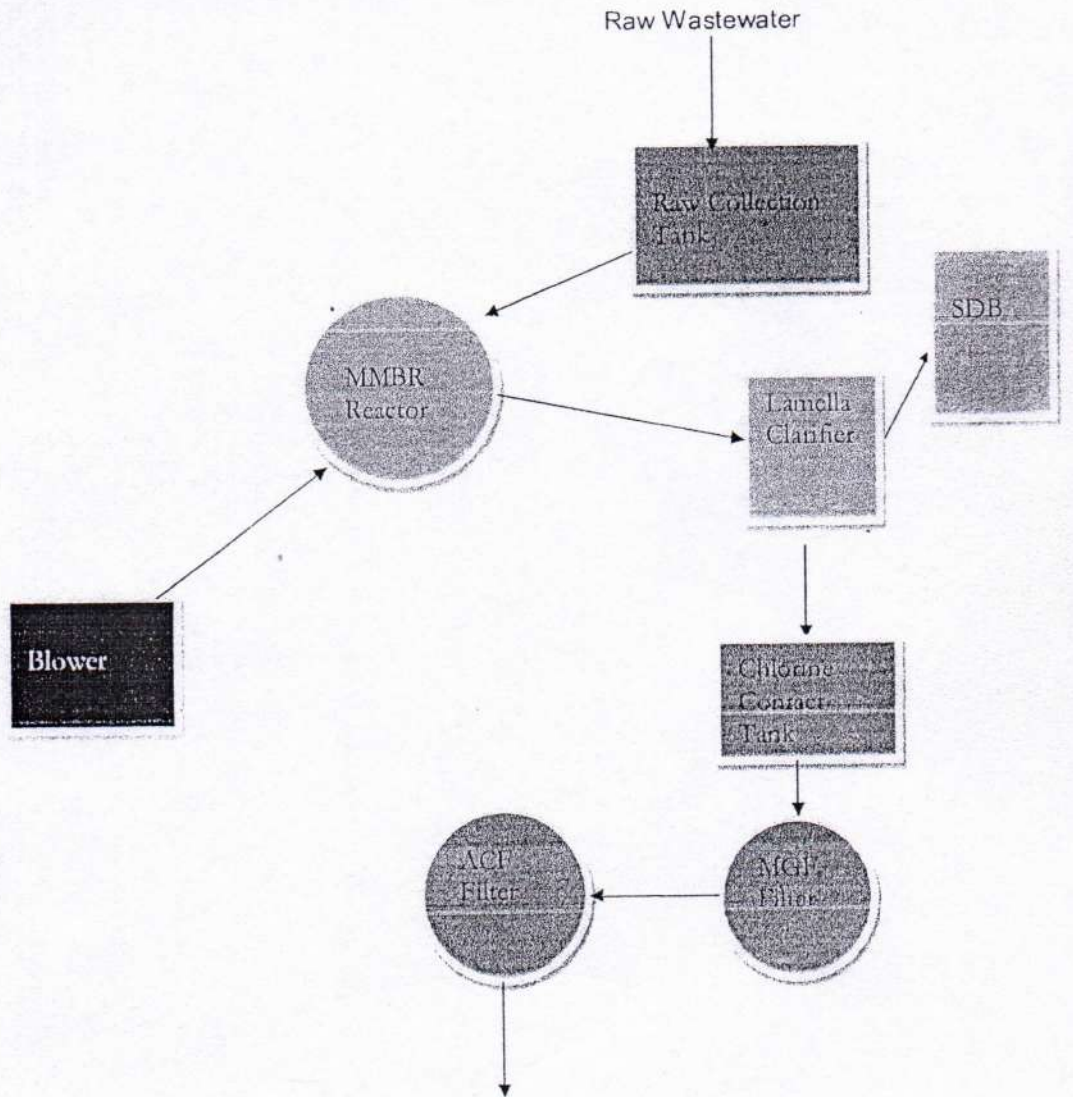

*C.S.*

Dr. Yashwantrao D. Kale  
M.S. Shalakyā (Ayu)  
Principal  
B.M. ...

*Z. Binodkar*



Estd : 1974

# BACKWARD CLASS YOUTH RELIEF COMMITTEE

140, "Rajvilla", Khamla Road, Nagpur - 440025.

Registration No. Maharashtra  
152 / 74 (N.)

Ph.No. : (0712) 2283543, 2283815. Fax : (0712) 2713658

Smt. Sumanmala B. Mulak  
Chairman

Shri. Rajendra B. Mulak  
Secretary

Shri. Yashraj R. Mulak  
Treasurer

Ref. No.: BCYRC/KH/BMAM/102/18-19

Date : 18.1.2018

## WORK ORDER CUM AGREEMENT

To,  
Krishna Gangaa Enviro System Pvt Ltd.  
LGF-3, Shree Ganesh Heights, Opp. Arun Automobiles,  
Khamla Square, Nagpur

Subject: Work Order for your firm for Execution of "Effluent Treatment Plant"  
Reference: your quotation dt. 22 Dec, 2017

Dear Sir,

With reference to above cited matter our management is pleased to place Work Order for your firm for Execution "Effluent Treatment Plant" at BMAM Premises, KDKCE Campus, Great Nag Road, Nandanvan, Nagpur-440009

### Form of Agreement

#### A) Description of Work Allotted, Approved Cost, Execution Time and Payment Terms

Execution of "Effluent Treatment Plant" at BMAM Premises, KDKCE Campus, Great Nag Road, Nandanvan, Nagpur-440009

Approved Cost of Plant: Rs. 200000 + 18% GST (In words: Rupees Two Lacs Only + 18% GST) Excluding Civil Cost

Execution Time: Within 30 Days from Work order

Payment Terms: As per Quotation

#### B) Other Terms & Condition

- The project for which the Work is being performed is the KDK College of Engineering campus situated at Nagpur.
- Agency will provide full time Supervision at the site to ensure that the works are being executed in general accordance with the specifications and drawings.
- Agency will take the safety of persons involved in the work and the surrounding public.
- Items of work and specifications shall be as per the schedule A.
- Scope of work includes execution of items complete in all respects. The scope includes labour, material, other resources necessary, guarantee of work, etc & taxes as applicable. Rates are for completed items of work.
- This letter & entire Documents form a part of contract and the same should be signed by you again for our records

Regards,

Secretary  
BCYRC

Dr. Yuwara S. Kale  
M. S. Shalakhya (Ayu)  
Principal  
B.M.A. College of Arts & Science  
Nagpur

Sprbhagadkam

# BACKWARD CLASS YOUTH RELIEF COMMITTEE

140, "Rajvilla", Khamla Road, Nagpur - 440025.

Registration No. Maharashtra  
152 / 74 (N.)

Ph.No. : (0712) 2283543, 2283815, Fax : (0712) 2713658

mt. Sumanmala B. Mulak  
Chairman

Shri. Rajendra B. Mulak  
Secretary

Shri. Yashraj R. Mulak  
Treasurer

Date: 13/06/19

## WORK ORDER CUM AGREEMENT

To,  
Krishna Ganga Enviro System Pvt Ltd.  
LGF-3, Shree Ganesh Heights, Opp. Arun Automobiles,  
Khamla Square, Nagpur

Subject: Work Order for your firm for Execution of "Sewage Treatment Plant"  
Reference: your quotation dt. 30 Oct, 2018 and subsequent Negotiation Meeting

Dear Sir,

With reference to above cited matter our management is pleased to place Work Order for your firm for Execution "Sewage Treatment Plant" at BMAM Premises, KDKCE Campus, Great Nag Road, Nandanvan, Nagpur-440009

### Form of Agreement

#### A) Description of Work Allotted, Approved Cost, Execution Time and Payment Terms

Execution of "Sewage Treatment Plant- 20 m<sup>3</sup>/D" at BMAM Premises, KDKCE Campus, Great Nag Road, Nandanvan, Nagpur-440009

Approved Cost of Plant: Rs. 854024 (In words: Rupees Two Lacs Only) Inclusive of all taxes and Transport

Execution Time: Within 120 Days from Work order

Payment Terms: As per Quotation

#### B) Other Terms & Condition

- The project for which the Work is being performed is the KDK College of Engineering campus situated at Nagpur.
- Agency will provide full time Supervision at the site to ensure that the works are being executed in general accordance with the specifications and drawings.
- Agency will take the safety of persons involved in the work and the surrounding public.
- Items of work and specifications shall be as per the schedule A.
- Scope of work includes execution of items complete in all respects. The scope includes labour, material, other resources necessary, guarantee of work, etc. & taxes as applicable. Rates are for completed items of work.
- Agency will take efforts for Issuing NOC from Government Authorities
- This letter & entire Documents form a part of contract and the same should be signed by you again for our records.

Regards,

  
Secretary  
BCYRC

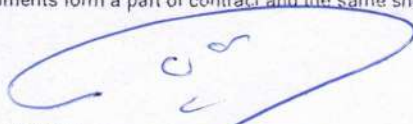
  
Dr. Yuwara D. Kale  
M. S. Shalakyá (Ayu)  
Principal  
B. K. ...

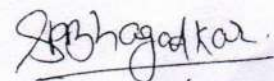



## KRISHNA GANGAA ENVIRO SYSTEM PVT LTD

LGF-3, SHRI GANESH HEIGHTS OPP. ARUN AUTOMOLIES  
KHAMLA SQUARE, NAGPUR-440015  
0712- 2248300 / 9422106527 /8605024327  
kgcon\_nagpur @ yahoo.com, info@kgespltd.com

### 3.0 SCOPE OF CLIENT

- Electricity : 3 Phase connection near proposed ETP site with earthing pit
- Civil Works as per KGES Design

S.No	Item	Eff. Volume	Remark
1	Raw Collection Tank	@ 12 cum	RCC
2	Chlorine Contact tank	@ 5 cum	RCC
3	Treated Water Tank	@ 8 cum	RCC
4	Sludge Drying Bed	1.0 m x 1.0 m – 2 nos	Brick Work as per site conditions

Cost of Civil Works at actual by client



*Prabhakar*

**KG****KRISHNA GANGAA ENVIRO SYSTEM PVT LTD**

LGF-3, SHRI GANESH HEIGHTS OPP. ARUN AUTOMOLIES  
 KHAMLA SQUARE, NAGPUR-440015  
 0712- 2248300 / 9422106527 /8605024327  
 kgcon\_nagpur @ yahoo.com, info@kgespltd.com

**4.0 SCOPE OF KRISHNA GANGAA ENVIRO SYSTEM**

S.No.	Item	Specification	Qty.	Make
1.	Raw wastewater feed pump	2.0 cum/hr @ 9.0m head with CI Impeller, solid handling pump	1 w + 1 s	Kirloskar/Crompton
2	MMBR Media	Recycled PP Media	Suitable Qty	Marvelous /Equivalent
3	Lamella Clarifier Media	UV stabilized	Suitable Qty	Marvelous/ Equivalent
4	MMBR Tank	5 mm thick MS Epoxy Tank	1 No	Fabricated
5	Lamella Clarifier Tank	5 mm thick MS Epoxy Tank	1 No	Fabricated
6	Blower with diffuser for aeration Motor	Twin Lobe blower	1 w + 1 s	Blower – IR / Airvak Diffuser – EPDM Fine Bubble and coarse bubble Diffuser
	Or Submersible Aerator	3 Phase motor of suitable HP	1 w + 1 s	Motor – Kirloskar/Greaves
7	Piping within battery limit (raw and treated wastewater piping not included)	UPVC & PVC with suitable valves	1 Job	Prince / Jain / Equivalent
8	Electrical panel with internal aluminum cabling	Non - compartmentalized Powder coated Panel	1 Job	Fabricated with L&T / Siemens Internals/CNS
9	Bleaching Powder Dosing Tank	HDPE	1 No	Reputed
10.	MGF Feed Pump	2.0 cum/hr @ 25.0m head with CI Impeller, solid handling pump	1 w + 1 s	Kirloskar/Crompton
11	MGF	Graded Filter with Sand	1 No	Reputed
12	ACF	Graded Filter with Carbon	1 No	Reputed

(STP- 20 m<sup>3</sup>/d)

Dr. Yuwara S. Kain  
 M. S. Shalakyā (AYU)  
 B.N.

30.10.2018 (Fabricated)

S. Bhogadkar

CERTIFICATE OF REGISTRATION  
The Societies Registration  
Act, 1860  
( Act XXI of 1860 )

Registration No. - Maharashtra / 152/74 (H).

It is hereby Certified that " BACKWARD  
CLASS YOUTH RELIEF COMMITTEE, NAGPUR " HAS  
THIS day been duly registered under the Societies  
Registration Act, XXI of 1860.

Given under my hand this  
24th day of September, 1974.

(Seal)

sd/-

Assistant Registrar  
of Societies.  
Nagpur Region, Nagpur.

TRUE COPY.

(PANJABRAO S. LAMBAT)  
DIST. NOTARY PUBLIC,  
Maharashtra State, NAGPUR  
(INDIA)



65  
Dr. Yashwantrao D. Kale  
M.S. Sthalakya (Ayu)  
B.M. ...

*Sh. Jagadkar*

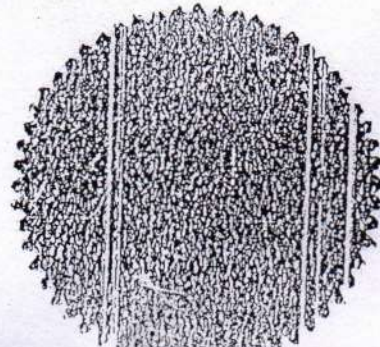

**K<sub>G</sub>****KRISHNA GANGAA ENVIRO SYSTEM PVT LTD**

LGF-3, SHRI GANESH HEIGHTS OPP. ARUN AUTOMOLIES  
KHAMLA SQUARE, NAGPUR-440015  
0712- 2248300 / 9422106527 /8605024327  
kgcon\_nagpur@yahoo.com, info@kgespltd.com

**6.0 COST BREAK-UP**

S.No.	Item	Amount
1.	Supply, erection and commissioning of Items 1 to 12 Listed in Table above	Rs 7,44,000=00 + Tax + Transportation
2.	Taxes relating to work	18 % GST Extra
3.	Transport from Nagpur to site , unloading , shifting to location	At actuals
4.	Civil Works	At actuals by client

**7. TERMS & CONDITIONS**

1] Client to provide water & electricity free of cost during construction & erection of plant at site.

**2] PAYMENT TERMS**

- 30 % Advance  
25 % On submission of functional designs  
40 % Against proforma invoice before material dispatch  
05 % on commissioning of the plant within 7 days

3] All warrantee of material would be 12months from date of supply for manufacturing defects only

**4] Disputes Redressal**

The agreement/work order / supply order would be subject all terms and conditions of Arbitration Act with Arbitrator being appointed as per mutual consent of both the parties. Further all legal matter would be subject to Jurisdiction of Nagpur Court

(STP- 20 m<sup>2</sup>/d)

30.10.2018 (Fabricated)

**K<sub>G</sub>**

**KRISHNA GANGAA ENVIRO SYSTEM PVT LTD**

LGF-3, SHRI GANESH HEIGHTS OPP. ARUN AUTOMOLIES

KHAMLIA SQUARE, NAGPUR-440015

0712- 2248300 / 9422106527 /8605024327

kgcon\_nagpur @ yahoo.com, info@kgespltd.com

5] Force Majeure Conditions

Should the delivery be delayed or prevented due to acts of god, fire, earthquake, civil commotion, government ordinance, import/export regulation, strikes, lockout, trade disputes, and difficulties in obtaining material, power shortage, accidents or any other causes which are beyond the control of supplier, suitable extension in delivery date shall be granted by the customer.

6] Escalation: If the material is not lifted within 4 months of order with advance, escalation as per prevalent market rate would be applicable.

7] No flow Condition: If within 1.5 months of erection, plant cannot be commissioned due to non availability of inflow, client to take dry test and release the payment,

Yours Truly,  
For Krishna Gangaa Enviro System Pvt Ltd  
-sd-  
[Dr Gajendr Sundar]

CM  
Dr. Yuvraj D. Kale  
M. S. Shalakyá (Ayu)  
Principala  
Bh...

*Bhagadke*

**K<sub>G</sub>**

**KRISHNA GANGAA ENVIRO SYSTEM PVT LTD**

LGF-3, SHRI GANESH HEIGHTS OPP. ARUN AUTOMOLIES

KHAMLA SQUARE, NAGPUR-440015

0712- 2248300 / 9422106527 /8605024327

kgcon\_nagpur @ yahoo.com, info@kgespltd.com

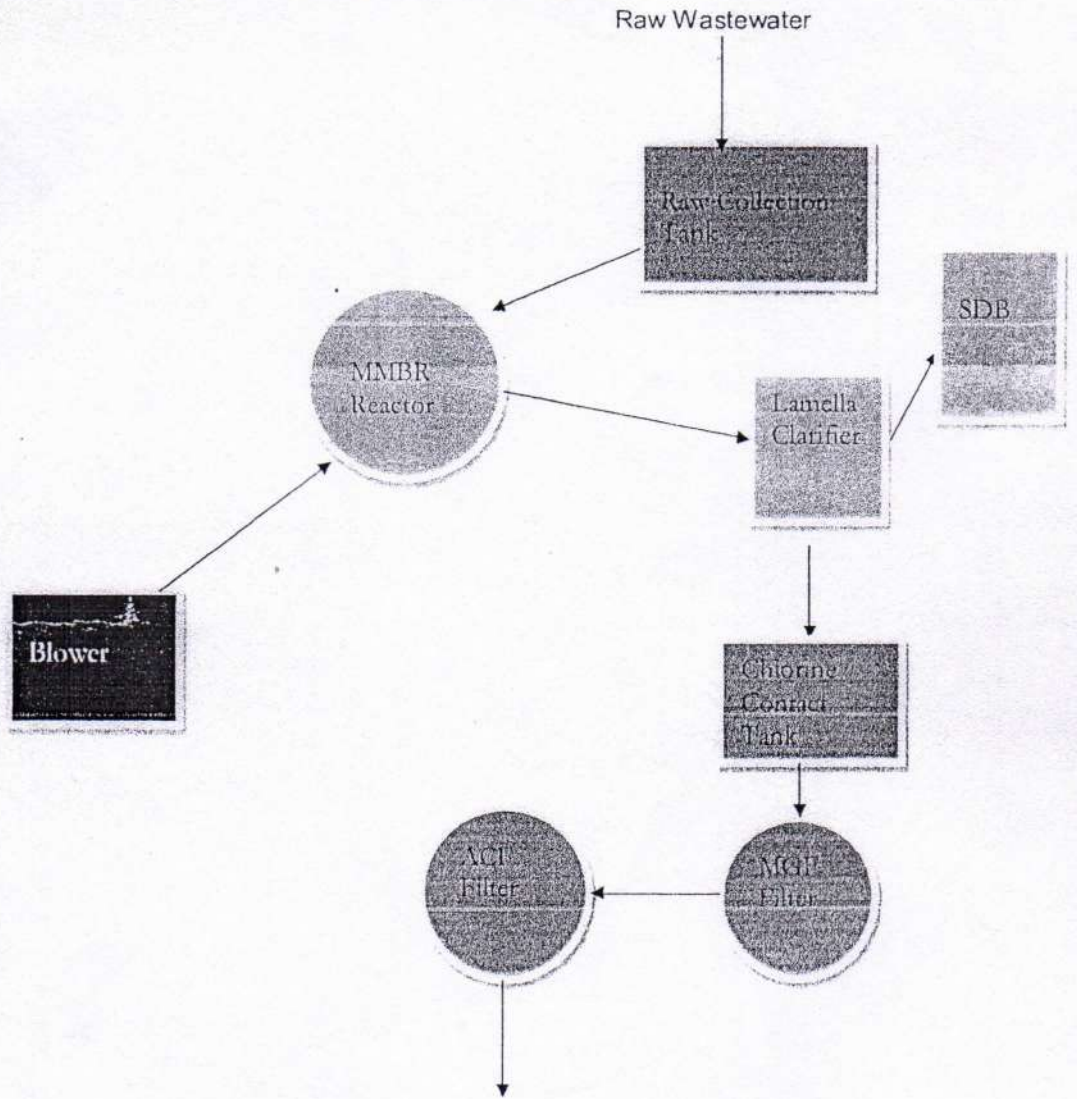

*Handwritten signature*  
**Dr. Yuwara D. Kale**  
**M. S. Shaikya (Ayu)**  
Principal  
B.M. ...

*Handwritten signature: J. B. ...*

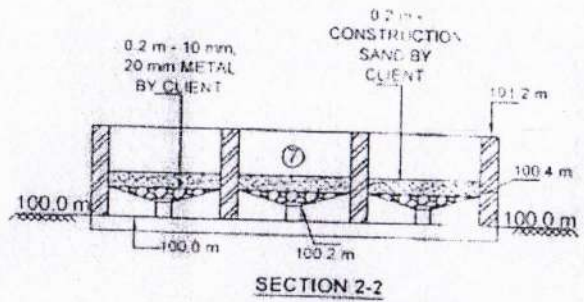
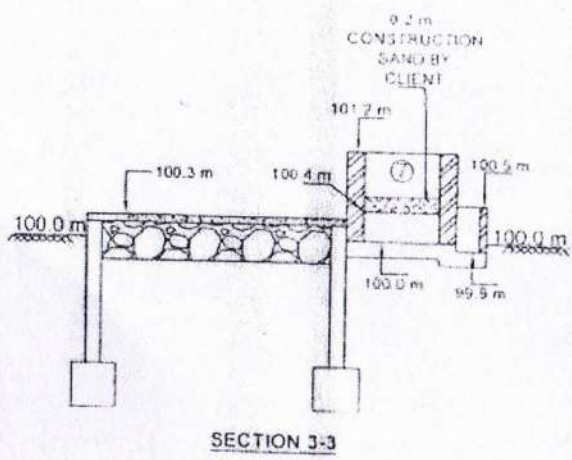
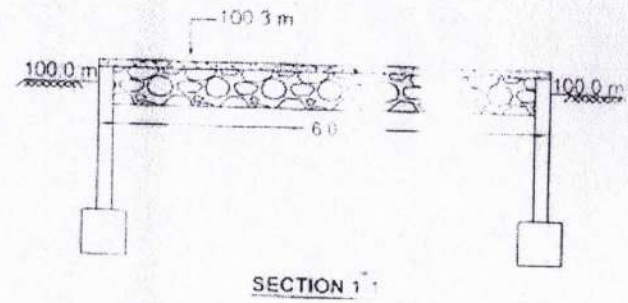
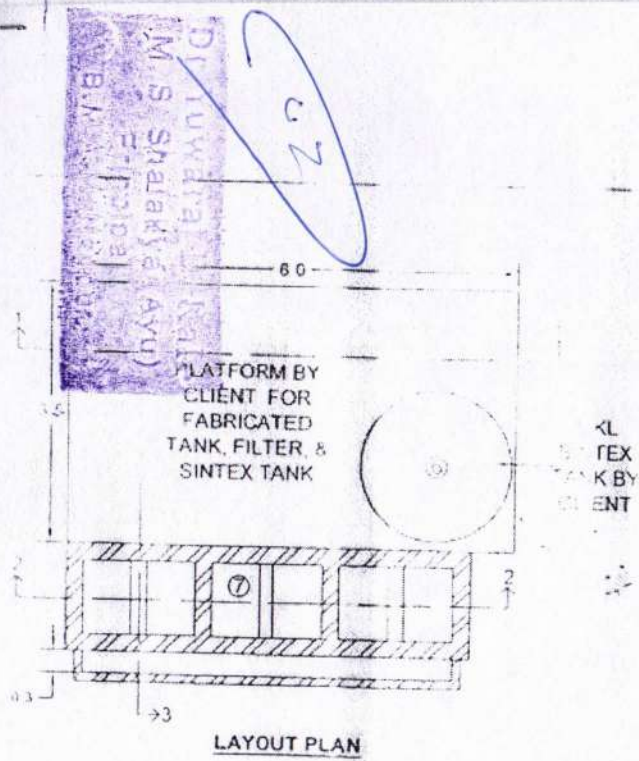

NOTE: 1) ALL DIMENSION ARE IN METERS  
2) DRAWING NOT TO SCALE  
3) ASSUME G.L. 100.0 m  
4) ASSUME INVERT LEVEL 0.0 m FROM G.L.

UNIT NO.	UNIT NAME	SIZE
1	COLLECTION TANK	0 m x 3.0 m x 1.2 m + 1.2 m top OR EXISTING TANK
2	AERATION TANK	FABRICATED
3	SECONDARY TUBE CLARIFIER	FABRICATED
4	MGF	1 NO
5	ACF	1 NO
6	CHLORINE CONTACT TANK	SINTEX - (BY CLIENT)
7	SLUDGE DRYING BEDS	1.5 m x 1.0 m x 1.2 m 3 NO'S

PROJECT - 20 KLD STP      DRG NAME - LAYOUT & SECTIONAL DETAILS

CLIENT - (MAM PREMISES, KDKCE CAMPUS, NAGPUR)

DRG. NO. - KGES/PLT/KDKCE/19-2001      DATE - 24.10.2019

CONSULTANT:

**KRISHNA GANGA ENVIRO SYSTEM PVT. LTD.**  
CONSULTING ENVIRONMENTAL ENGINEERS & CONTRACTOR  
T, NAVNATH SOCIETY, BUDHAR MARKET ROAD, NEAR MHP  
INDIAN GAS AGENCY, PAPER CL TO RAK, WAY LINE,  
HARENDRA NAGAR EXTENSION, NAGPUR-440015  
PH. NO. - 91-777085947    CELL - 91-8005024327  
email - kgscon\_nagpur@yahoo.com    info@kgspltd.com



## Purchase Order

PO No:- Innovinc/Ultracare/KDK/21-22/004

Date:- 04.03.2022

To,  
**M/S POWERICA LIMITED**  
 Plot No. 191, 2<sup>nd</sup> Floor,  
 Shiv Chhaya Building,  
 Ram nagar Nagpur.- 440033. (MH)  
 Contact No – 9921545021  
 Contact Person – Mr. Bhupesh Walde  
 Email Id - [bhupesh.walde@powericaitd.com](mailto:bhupesh.walde@powericaitd.com)

**Subject:-** Purchase Order supply of 200kVA DG Set with AMF Control panel for Innovinc -Ultracare Hospital

**Reference:-** 1) Your quotation No : PLN/QTN/2022/40 REV Dated 03.03.2022  
 2) Our technical discussion and negotiation dated – 03.03.2022 & 05.03.2022.

Dear Sir,

We are pleased to release Purchase Order for supply of 200KVA Generator set of Cummins Make for our innovinc Ultracare Hospital Project at KDK Engineering Collage, Nandanvan, Nagpur.

Details of Product as below:

SL NO.	Description	Qty (Nos)	Rate (Rs)	Amount (Rs)
1	200 kVA / 160 KW Electric Generating Set is incorporating CUMMINS Model QSB6.7-G15, Radiator Cooled Diesel Engine developing 256 BHP at 1500 rpm, Complete with standard accessories and Coupled To Stamford Alternator 200 KVA / 160 KW, rated at 415 Voits at 0.8 PF, Mounted on a common base frame, AVM Pads fitted, Residential Silencers, First fill of Lube Oil & Coolant, with Cummins battery, with AMF control panel suitable for 200 KVA Dg set. • Soundproof & weatherproof Acoustic Enclosure. • DG set CPCB II approved.	1	12,85,000	12,85,000.00
Basic Amount:-				12,85,000.00
GST @ 18%:-				2,31,300.00
Total Amount:-				15,16,300.00

Total Amount in Rs.:- Fifteen Lac, Sixteen Thousand, three Hundred only.

### Terms and Condition

1) Price:- The Price are Firm & F.O.R. up to KDK Engineering collage Nagpur.  
 Price variation clause is not applicable to this Purchase order at any point of time.

2) Taxes:- GST will be charged extra @ 18% as mention above.

*(Signature)*  
 M. S. Sharanya Ayur  
 Principal  
 KDK Engineering Collage  
 Nandanvan, Nagpur

- 3) **Freight & Transit Insurance:-** Inclusive, as mention above.
- 4) **Delivery Period:-** The supplier should deliver the Generator and allied material to the designated location within 2-3week from the date of Purchase order & advance.
- 5) **Payment Terms:-** 30% advance along with Purchase Order and remaining prior to dispatch.
- 6) **Defect Liability:-** As per Warranty/Guarantee Clause given in your quotation ref: LN/QTN/2022/40 REV Dated 03.03.2022.
- 7) **Installation & Commissioning:-** The above prices are exclusive of Installation and commissioning of Generator set; however supervision will be done by M/s. Powerica Ltd.
- 8) **Guarantee / Warrantee :-** 2 Year on 200kVA DG set and 5 critical parts namely : Crank shaft, Cam Shaft, Cylinder Head, Connecting Rod, and Cylinder Block will be under special warranty for 5 Years from the supply or 5000 hours whichever is earlier.
- 9) **Liquidated Damages :-** The Penalty by 0.5% per day of the order value on undelivered material would be applicable in case of delay of material after delivery period, wherever applicable. This penalty would be subject to maximum of 5% of the order value, later which this order stands cancelled & necessary cost for reordering of material would be recovered from the supplier.
- 10) **Packing, Loading & Unloading:-** The supplier would be responsible for packaging and loading of material at no additional cost. Unloading of material at Innovinc scope.
- 11) **Billing Address:-** INNOVINC HEALTHCARE PVT LTD  
KDK College, Ayurvedic building  
Nagpur, 440017  
Contact person: CA Vishal Mandavgade -9673046156  
Our GST No is - 27AAFIC13606L1ZG
- 12) **Delivery address:-** INNOVINC HEALTHCARE PVT LTD  
KDK College, Ayurvedic building  
Nagpur, 440017
- 13) **Beneficiary:-** M/S POWERICA LIMITED  
Plot No. 191, 2<sup>nd</sup> Floor,  
Shiv Chhaya Building,  
Ram nagar Nagpur.- 440033. (MH)
- 14) **Documents required From Supplier to Site Store:-** Two sets of the following documents have to be submitted at the site along with the materials. Tax Invoice, GST Invoice & E-waybill (duplicate-Transporter), Delivery Challan, Packing List, Lorry Receipt ( with proper site address),(if applicable), Test Certificate, Warranty Certificate, Technical details.
- 15) **Training:** Complete Training on the Generator will be given to our staff/officer at free of cost.
- 16) **Sales after Service Details:** The supplier has to provide free service during the warranted period.

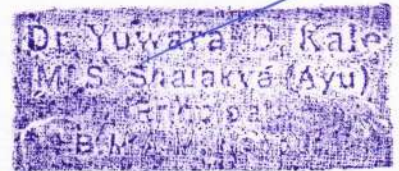

Principal  
Bhamburda

17) Jurisdiction:- The contract/ purchase order is subject to Nagpur Jurisdiction.

18) Remarks:- Time is the essence of this contract & you will strictly ensure the timely delivery of your material as described above. Please find this purchase order in two copies. Please retain the Original and return to us the second copy duly endorsing the same as accepted within 3 days from receipt of Purchase Order; any typographical mistake subject to correction.

Thanks and Regards  
For, INNOVINC HEALTHCARE PVT LTD

Sachin Ganvir  
Purchase Head

CA Vishal Mandavgane  
Commercial Head



Bhausaheb  
Maharashtra, Nagpur

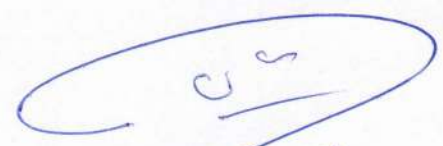

Dr. Yuwara D. Kale  
M.S. Shastry (Ayu)  
B.K. Shastry

B-12



# TAX INVOICE

Invoice# INV/24-25/132

### NS ENGINEERING

Plot No. 124, Sadhbhavana Nagar  
Near KDK College, Nandanvan  
Nagpur Maharashtra 440009  
India  
GSTIN 27AAMFN8576A1ZY

#### Bill To

**BHAUSAHEB MULAK AYURVEDIK COLLEGE**  
Bhousaheb Mulak Ayurvedik College, Near KDK College  
Campus,  
Nandanvan  
Nagpur  
440009 Maharashtra  
India

#### Ship To

Bhousaheb Mulak Ayurvedik College, Near KDK College  
Campus,  
Nandanvan  
Nagpur  
440009 Maharashtra  
India

Place Of Supply: Maharashtra (27)

Invoice Date	Terms	Due Date	P.O.#
03/03/2025	Due On Receipt	03/03/2025	Verbal

#	Item & Description	HSN/SAC	Qty	Rate	Amount
1	MISC I ENGINEERING CHARGES Providing electrical Safety audit for Bhousaheb Mulak Ayurvedik College with all safety reports and certificates.	995630	1.00 Set.	30,000.00	30,000.00

Sub Total 30,000.00

CGST9 (9%) 2,700.00

SGST9 (9%) 2,700.00

**Total ₹35,400.00**

**Balance Due ₹35,400.00**

Total In Words: **Rupees Thirty-Five Thousand  
Four Hundred Only**

G.L.

Dr. Yuwaraj D. Kale  
M.S. Shalakyā (Ayu)  
Principal

#### Notes

For NEFT/RTGS  
KOTAK MAHINDRA BANK  
A/C. 8237860461 CURRENT A/C.  
IFSC CODE: KKBK0001837  
BRANCH: GANDHIBAUG

#### Terms & Conditions

Kindly made the payment as per purchase order terms.

S

Dr. Yuwaraj D. Kale  
M.S. Shalakyā (Ayu)  
Principal

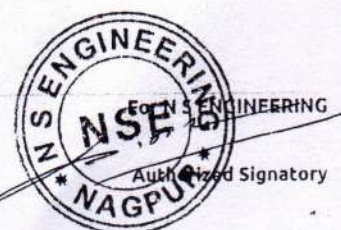

**Purchase Order**

PO No:- Innovinc/Ultracare/KDK/21-22/004

Date:- 04.03.2022

To,  
**M/S POWERICA LIMITED**  
Plot No. 191, 2<sup>nd</sup> Floor,  
Shiv Chhaya Building,  
Ram nagar Nagpur.- 440033. (MH)  
Contact No – 9921545021  
Contact Person – Mr. Bhupesh Walde  
Email Id - [bhupesh.walde@powericaltd.com](mailto:bhupesh.walde@powericaltd.com)

**Subject:-** Purchase Order supply of 200kVA DG Set with AMF Control panel for Innovinc -Ultracare Hospital.

**Reference:-** 1) Your quotation No : PLN/QTN/2022/40 REV Dated 03.03.2022  
2) Our technical discussion and negotiation dated – 03.03.2022 & 05.03.2022.

Dear Sir,  
We are pleased to release Purchase Order for supply of 200kVA Generator set of Cummins Make for our Innovinc-Ultracare Hospital Project at KDK Engineering Collage, Nandanvan, Nagpur.

Details of Product as below:

SL NO.	Description	Qty (Nos)	Rate (Rs)	Amount (Rs)
1	200 kVA / 160 KW Electric Generating Set is incorporating CUMMINS Model QSB6.7-G15, Radiator Cooled Diesel Engine developing 256 BHP at 1500 rpm, Complete with standard accessories and Coupled To Stamford Alternator 200 KVA / 160 KW, rated at 415 Volts at 0.8 PF, Mounted on a common base frame, AVM Pads fitted, Residential Silencers, First fill of Lube Oil & Coolant, with Cummins battery, with AMF control panel suitable for 200 KVA Dg set. • Soundproof & weatherproof Acoustic Enclosure. • DG set CPCB II approved.	1	12,85,000	12,85,000.00
Basic Amount:-				12,85,000.00
GST @ 18%:-				2,31,300.00
Total Amount:-				15,16,300.00

Total Amount in Rs.:- Fifteen Lac, Sixteen Thousand, three Hundred only.

**Terms and Condition**

1) **Price:-** The Price are Firm & F.O.R. up to KDK Engineering collage Nagpur. Price variation clause is not applicable to this Purchase order at any point of time.

2) **Taxes:-** GST will be charged extra @ 18% as mention above.

Dr. Yuwara D. Kale  
M.S. Shalakyá (Ayu)  
Principa  
B.M. 12/12/2022

- 3) **Freight & Transit Insurance:-** Inclusive, as mention above.
- 4) **Delivery Period:-** The supplier should deliver the Generator and allied material to the designated location within 2-3week from the date of Purchase order & advance.
- 5) **Payment Terms:-** 30% advance along with Purchase Order and remaining prior to dispatch.
- 6) **Defect Liability:-** As per Warranty/Guarantee Clause given in your quotation ref: LN/QTN/2022/40 REV Dated 03.03.2022.
- 7) **Installation & Commissioning:-** The above prices are exclusive of Installation and commissioning of Generator set; however supervision will be done by M/s. Powerica Ltd.
- 8) **Guarantee / Warrantee :-** 2 Year on 200kVA DG set and 5 critical parts namely : Crank shaft, Cam Shaft, Cylinder Head, Connecting Rod, and Cylinder Block will be under special warranty for 5 Years from the supply or 5000 hours whichever is earlier.
- 9) **Liquidated Damages :-** The Penalty by 0.5% per day of the order value on undelivered material would be applicable in case of delay of material after delivery period, wherever applicable. This penalty would be subject to maximum of 5% of the order value, later which this order stands cancelled & necessary cost for reordering of material would be recovered from the supplier.
- 10) **Packing, Loading & Unloading:-** The supplier would be responsible for packaging and loading of material at no additional cost. Unloading of material at Innovinc scope.
- 11) **Billing Address:-** INNOVINC HEALTHCARE PVT LTD  
KDK College, Ayurvedic building  
Nagpur, 440017  
Contact person: CA Vishal Mandavgade -9673046156  
Our GST No is - 27AAFCI3606L1ZG
- 12) **Delivery address:-** INNOVINC HEALTHCARE PVT LTD  
KDK College, Ayurvedic building  
Nagpur, 440017
- 13) **Beneficiary:-** M/S POWERICA LIMITED  
Plot No. 191, 2<sup>nd</sup> Floor,  
Shiv Chhaya Building,  
Ram nagar Nagpur.- 440033. (MH)
- 14) **Documents required From Supplier to Site Store:-** Two sets of the following documents have to be submitted at the site along with the materials. Tax Invoice, GST Invoice & E-waybill (duplicate-Transporter), Delivery Challan, Packing List, Lorry Receipt ( with proper site address),(if applicable), Test Certificate, Warranty Certificate, Technical details.
- 15) **Training:** Complete Training on the Generator will be given to our staff/officer at free of cost.
- 16) **Sales after Service Details:** The supplier has to provide free service during the warrantee period.

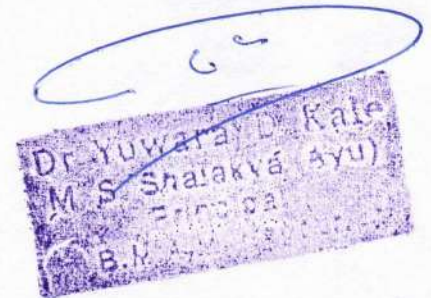

17) **Jurisdiction:-** The contract/ purchase order is subject to Nagpur Jurisdiction.

18) **Remarks:-** Time is the essence of this contract & you will strictly ensure the timely delivery of your material as described above. Please find this purchase order in two copies. Please retain the Original and return to us the second copy duly endorsing the same as accepted within 3 days from receipt of Purchase Order; any typographical mistake subject to correction.

Thanks and Regards  
For, **INNOVINC HEALTHCARE PVT LTD**

Sachin Ganvir  
Purchase Head

CA Vishal Mandavgane  
Commercial Head

02

Dr. Yuvraj B. Kale  
M.S. (Shiksha Ayu)  
Principal  
B.M. ...



महाराष्ट्र शासन

## मालमत्ता पत्रक

ULPIN: 58504076370

[महाराष्ट्र जमीन महसूल (गाव, नगर व शहर भूमापन) नियम, १९६९ यातील नियम ७ नमुना "ड"]



58504076

गाव/पेठ : नागपूर-शिट नंबर २४९

तालुका/न.भू.का. : न.भू.अ.१ नागपूर

जिल्हा : नाग

नगर भूमापन क्रमांक	शिट नंबर	प्लॉट नंबर	क्षेत्र चौ.मी.	धारणाधिकार	शासनाला दिलेल्या आकारणीचा किंवा माझ्याचा तपशील आणि त्याच फेरतपासणीची नियत वेळ
१०१	२४९		६५१५८.००	क	

सुविधाधिकार :

हक्काचा मूळ धारक :

वर्ष : १९७१

पट्टेदार :

इतर भार :

इतर शेरें :

वार्षिक भूमाटक १९.८०/-रूपये फक्त.

दिनांक	व्यवहार	खंड क्रमांक	नविन धारक(वा), पट्टेदार(प) किंवा भार (इ)	साक्षात्कन
02/04/1984	चौकशी पंजीचे अभिलेखा - प्रमाणे व ऍडीशनल तह सीलदार एन.ए.ए. नागपूर यांचे गैरकृषी रेव्हेंयु केस नं.३५२ एन.ए.पी/३६/८२-८३ रामकृष्ण दि.१९/४/७३ व मैनी दि.३०/४/७३ ला भेटवत झाल्यावरून वारस दर्ज.		H [ (घा.)श्री.रामकृष्ण दशरथ घाटोळे. ] [ श्रीमती मैनी वि.दशरथ घाटोळे. ] [ श्रीमती भूली वि.दशरथ घाटोळे ] [ श्री मदन रामकृष्ण घाटोळे ] [ श्री सुधाकर रामकृष्ण घाटोळे. ] [ श्रीअण्णा रामकृष्ण घाटोळे ] [ श्रीमती सोनाबाई रामकृष्ण . घाटोळे ]	सही- 04/05/1984 न.भू.अ.क्र.१ नागपूर
02/04/1984	खरेदी हक्काने रजि.अ.क्र.२४६० व क्र.२४६१/८४ दिनांक ६/१०/८२ ला किंमत रूपये अनुक्रमे ५,५३,५००/- व ८,५४,७५०/-रूपये.		H वेलकम को ऑप रेटीव्ह हाऊसींग सोसायटी लि नागपूर तर्फे सचिव श्री. भालचंद्र नारायणराव जोशी	सही- 02/04/1984 न.भू.अ.क्र.१ नागपूर
04/11/1996	खरेदी हक्काने र.न.६ दि.१/१/९६ अ.न.०२ किंमत रु.१६,०००/- ला २७९०० चौ.फूट प्रमाणे नाव दर्ज		H श्री दिपक नरेन्द्र मीश्रा	फेरफार क्र. ३९० प्रमाणे सही- 04/11/1996 न.भू.अ.क्र.१ नागपूर
29/04/2008	राजस्व नामला क्रमांक ३/१-६५ सन ६६-६७ अन्वये खसरा क्रमांक ३२१ क्षेत्र ७.९८ हे आर संपादन		H नागपूर सूधार प्रस्थास नागपूर	फेरफार क्र. ७४६७ प्रमाणे सही- 29/04/2008 न.भू.अ.क्र.१ नागपूर
29/04/2008	भाडेपट्टा र.द.क्र.५४२९ /०७ दिनांक २४/१२/२००७ अन्वये क्षेत्र ६६.०७८.८२ चौमी		H बँकवर्ड क्लास यूथ रिलिफ कमिटी मार्फत अध्यक्ष श्री. भाऊसाहेब मुळक	फेरफार क्र. ७४६८ प्रमाणे सही- 29/04/2008 न.भू.अ.क्र.१ नागपूर
11/12/2009	खरेदिने र.द.क्र. ७६५६ दि. २१/१०/८२ अन्वये प्लॉट नंबर २१ क्षेत्र २२२.०० चौ.मी. व २४६० व क्र. २४६१/८४ दि. १९/४/७३ व मैनी दि. ३०/४/७३ ला भेटवत झाल्यावरून वारस दर्ज. विक्री करपारारे नांव कायम.		H श्री अशोककुमार भैयालाल पशिने	फेरफार क्र. ८८५५ प्रमाणे सही- 11/12/2009 न.भू.अ.क्र.१ नागपूर

03/2017	भाडेपट्ट्याने:- र.द.क्र. २०६६ दि २०/३/०३ अन्वये नागपूर सुधार प्रस्थास यांनी कडून फ्लॉट नं.३० क्षेत्र २५.५२ चौ.मी. जागा दि ३०/११/१० ते दि ०९/११/२०२० पावतो भाडेपट्ट्याने दिल्याने पट्टेदाराचे नाव दर्ज	H	श्री. मोहम्मद सोब्रती अंसारी	फेरफार क्र. ७३३९ प्रमाणे सही- 09/03/2017 न.भू.अ.क्र.१ नागपूर
09/03/2017	भाडेपट्ट्याने:- र.द.क्र. २६ दि ११/११ अन्वये नागपूर सुधार प्रस्थास नागपूर यांनी फ्लॉट नं.३७ क्षेत्र २५.५२ चौ.मी. दि १०/११/८९ ते दि ०९/११/२०१९ पावतो भाडेपट्ट्याने दिल्याने पट्टेदाराचे नाव दर्ज	H	श्रीमती प्रमिला तुकाराम वाघ	फेरफार क्र. ७३४४ प्रमाणे सही- 09/03/2017 न.भू.अ.क्र.१ नागपूर
08/04/2017	भाडेपट्ट्याने:- र.द.क्र. २२६२ दि २०/५/११ अन्वये नागपूर सुधार प्रस्थास, नागपूर यांनी ख.नं.३२५ मधील फ्लॉट नं.३४ क्षेत्र २५.५२ चौ.मी. दि १४/३/२१ पावतो भाडेपट्ट्याने दिल्याने पट्टेदाराचे नाव दर्ज	H	श्री. मारोती रामाजी उईके पहा गहानबोझा फे.क्र.८२०६	फेरफार क्र. ७९२९ प्रमाणे सही- 08/04/2017 न.भू.अ.क्र.१ नागपूर
19/04/2017	भाडेपट्ट्याने:- र.द.क्र. १९२ दि २६/२/०३ अन्वये नागपूर सुधार प्रस्थास यांनी फ्लॉट नं.२० क्षेत्र २५.५२ चौ.मी. दि ३०/११/१९९० ते २९/११/२० पावतो भाडेपट्ट्याने दिल्याने पट्टेदाराचे नाव दर्ज	H	[ श्रीमती चंद्रभागाबाई रामाजी साठवणे फे.क्र.७४६६ ]	फेरफार क्र. ७४६५ प्रमाणे सही- 19/04/2017 न.भू.अ.क्र.१ नागपूर
19/04/2017	भाडेपट्ट्याने:- र.द.क्र. १९९ दि २४/१/१७ अन्वये रक्कम रु. ४,६५,०००/ मध्ये धारक श्रीमती चंद्रभागाबाई रामाजी साठवणे यांनी फ्लॉट नं.२० क्षेत्र २५.५२ चौ.मी. विकल्याने धारकाचे नाव कमी खरेदी घेणार नाव दर्ज	H	श्री. गजानन रामाजी साठवणे	फेरफार क्र. ७४६६ प्रमाणे सही- 19/04/2017 न.भू.अ.क्र.१ नागपूर
21/11/2017	भाडेपट्ट्याने:- र.द.क्र. १९३ दि २६/२/०३ अन्वये नागपूर सुधार प्रस्थास यांनी ख.नं.३२९ मधील फ्लॉट नं.७१ क्षेत्र २५.५२ चौ.मी. दि ०५/०६/१९९१ ते ०४/०६/२१ पावतो भाडेपट्ट्याने दिल्याने पट्टेदाराचे नाव दर्ज	H	श्री. सुरेश कृष्णाजी उदापुरे	फेरफार क्र. ८११६ प्रमाणे सही- 21/11/2017 न.भू.अ.क्र.१ नागपूर
12/12/2017	भाडेपट्ट्याने:- र.द.क्र. ४४११ दि ३/९/०३ अन्वये नागपूर सुधार प्रस्थास नागपूर यांनी ख.नं.३२९ मधील फ्लॉट नं.४८ क्षेत्र २५.५२ चौ.मी. जागा दि २६/१२/१९८९ ते २५/१२/२०१९ पावतो भाडेपट्ट्याने दिल्याने पट्टेदाराचे नाव दर्ज	H	श्री. मनोहर गुलाबराव दाघमारे	फेरफार क्र. ८१८३ प्रमाणे सही- 12/12/2017 न.भू.अ.क्र.१ नागपूर
19/12/2017	गहाणखतान्वये:- र.द.क्र. ४९११ दि २६/१०/१७ अन्वये धारक श्री. मारोती रामाजी उईके यांनी ख.नं.३२९ मधील फ्लॉट नं.३४ क्षेत्र २५.५२ चौ.मी. वर दि विदर्भ प्रिमीयर को.ऑप हाऊसिंग सोसायटी लि.नागपूर कडून रक्कम रु.७,००,०००/ कर्ज घेतल्याने बँकेचा गहाण बोझा दर्ज	H	दि विदर्भ प्रिमीयर को.ऑप हाऊसिंग सोसायटी लि.नागपूर	फेरफार क्र. ८२०६ प्रमाणे सही- 19/12/2017 न.भू.अ.क्र.१ नागपूर
05/09/2022	भाडेपट्टा नोंद - सह दु.नि. नागपूर २ यांचेकडील र.द.क्र. १००/१९९८ दिनांक ०२/०९/१९९८ अन्वये नागपूर सुधार प्रस्थास नागपूर यांनी दि. २८/१०/१९८९ पासून ते दि. २९/१०/२०१९, ३० वर्ष ० महिने कालावधीकरिता वार्षिक रक्कम रु. ५६४ दर साल या दराने दिल्याने भाडेपट्टादाराचे नावाची नोंद केली .	L	सह दु.नि. नागपूर २ 900/1998 02/09/1998 शांताबाई गोविंदराव मूते फ्लॉट नं. २६ २५.६२ चौ.मी	फेरफार क्र. १ प्रम सही- 05/09/2022 न.भू.अ. न.भू.अ. नागपूर

हि मिळकत पत्रिका (दिनांक 05/09/2022 04:09:45 PM रोजी) डिजिटल स्वाक्षरी केली असल्यामुळे त्यावर कोणत्याही सही शिक्काची आवश्यकता नाही.

मिळकत पत्रिका डाउनलोड दिनांक 18/10/2022 04:10:32 PM

वेळता पडताळणी साठी <https://digitalsatbara.mahabhumi.gov.in/DSLR/Login/VerifyPropertyCard> या संकेत स्थळावर 091510002338156 हा क्रमांक वापरावा.

Dr. Yuwana D. Kale  
M. S. Shalavá Ayu  
Prasanna  
B.M. Shalavá Ayu



**BSNL**  
Connecting Bharat  
Security • Affordably • Reliably

C-a&b

Account No: 1109920321

Invoice No: WMHR2601357760

Invoice Date: 03-FEB-2026

USAGE PERIOD:

01-JAN-2026 to 31-JAN-2026

Fixed Monthly Charge Period and Plan Detail available on Page 3

Tax Invoice

PRINCIPAL BHAUSAHEB  
MULAKAYURVED COLLEGE

BHAUSAHEB MULAK  
AYURVED,NAGPUR,,KDK CAMPUS-  
MAHARASHTRA-440009

TELEPHONE NUMBER

0712-2955063

AMOUNT PAYABLE

₹1001.00

DUE DATE

18-FEB-2026

GSTIN

**PAY NOW**

24x7 Toll Free Helpline  
Call or WhatsApp Hi to  
1800 4444

Account Summary

PREVIOUS BALANCE	-	PAYMENT RECEIVED	+	ADJUSTMENTS	+	CURRENT CHARGES	=	TOTAL DUE	=	AMOUNT PAYABLE
₹ 1001.01		₹ 1002.00		₹ 0.00		₹ 1001.82		₹ 1000.83		₹ 1001.00

Credit Limit: 1273.50 | Deposit Amount: 849.00 |

Amount in Words: Rupees One Thousand One Only

Summary of Current Charges

Description	Amount ₹
Recurring Charges	849.00
One Time Charges	0.00
Usage Charges	0.00
Miscellaneous Charges	0.00
Discounts	0.00
Late Fee	0.00
<b>Total Taxable (Rs.)</b>	<b>849.00</b>
<b>Tax</b>	<b>152.82</b>
<b>Total Current Charges</b>	<b>1001.82</b>
<b>Tax Details</b>	<b>Tax Rate Amount ₹</b>
CGST @9%	9.00% 76.41
SGST/UTGST @ 9%	9.00% 76.41



Scan QR to make Online UPI

Accounts Officer (TR)  
For Billing related issues:

Dear Customer, Soft copy of this Bill has been mailed to your ID hospitalbmam1992@gmail.com. If mail ID is incorrect, please update correct ID at www.selfcare.bsnl.co.in

Always On  
Always Fast  
Always BSNL

**BSNL FTTH**

Ultra-fast speed upto 1 Gbps

FTTH online booking available now

Smart Home Ready

Get your FTTH Now

Enjoy uninterrupted connectivity for everything you love online.



PORTAL QR Code (for Payment)

PAYMENT SLIP

Please make crossed Cheque/DD/Pay Order for Amount Payable (Rounded Up) in favour of AO (Cash), BSNL, NGP.

BHARAT SANCHAR NIGAM LIMITED

Cash  Cheque/DD  Credit/Debit Card

Cheque/DD No. \_\_\_\_\_ Date \_\_\_\_\_ Amount ₹ 1001.00

Bank \_\_\_\_\_ Branch \_\_\_\_\_

Signature \_\_\_\_\_

Invoice No	WMHR2601357760
Invoice Date	03-FEB-2026
Account No	1109920321
Phone No	0712-2955063
Due Date	18-FEB-2026
Amount Payable	₹ 1001.00

Dr. Yuvraj D. Kale  
M. S. Shelakya (Ayu)  
B.M.

# PREPAID Wi-Fi MONTHLY STATEMENT



**Yuvaraj Dhanraj Kale**

Bhauasaheb mulak ayurved Mahavidyalaya, Darshan Colony  
Nandanvan Nagpur Maha rashtra India, Nandanwan  
nagpur near kdk collage, KDK College Road, Nagpur, Na  
gpur, Maharashtra, 440024  
Nagpur Maharashtra 440024  
Email Address: 1989ayu07bmam@gmail.com  
Alternate Mobile Number: 8484881844

**Your Plan: 999 WiFi 200Mbps (Advance Rental)**  
Valid till: 20 Jul 2026

Number of Connections: 1  
Statement Date: 27 Dec 2025  
Statement Period: 26 Nov 2025 to 25 Dec 2025

<b>Total Available Balance</b>	
<b>₹-6858.47</b>	
Recharge via <b>Airtel Thanks App</b> <a href="http://www.airtel.in/pay">www.airtel.in/pay</a>	
Scan & pay via any UPI Apps Powered by 	

Opening Balance	Total Recharges	Credits	This month's charges	Closing Balance
₹-7860.46	₹0.00	₹0.00	+ ₹1001.99	= ₹-6858.47

This Month's Charges Summary				
Services	Connections	Plan Charges	Other Charges	Total
Wi-Fi- 071219149071_wifi	1	₹849.15	₹0.00	₹849.15
Taxes (GST)	-	₹152.84	₹0.0	₹152.84
<b>This month's charges</b>				<b>₹1001.99</b>
Opening Balance	-	-	-	₹-7860.46
<b>Closing Balance</b>				<b>₹-6858.47</b>

**Total : minus Six Thousand Eight Hundred Fifty Eight Rupees and Forty Seven Paise Only**

Bills & Payments Summary					
Month	Opening Balance (A)	Total Recharges (B)	Adjustment (C)	This month's charges (D)	Closing Balance (A+B+C+D)
December'25	-7860.46	0.0	0.0	1001.99	-6858.47
November'25	-8862.45	0.0	0.0	1001.99	-7860.46
October'25	-9864.44	0.0	0.0	1001.99	-8862.45
September'25	-10866.43	0.0	0.0	1001.99	-9864.44

# PREPAID Wi-Fi MONTHLY STATEMENT



**Yuwaraj Dhanraj Kale**

BMAM PRINCIPAL OFFICE KDK CAMPUS, Nagpur  
Maharashtra 440024 India, KDK CAMPUS,  
S, Nandanvan,, Nagpur, Maharashtra, 440024  
Nagpur Maharashtra 440024  
Email Address: 1989ayu0170bmam@gmail.com  
Alternate Mobile Number: 8484881844

**Your Plan: 799 WiFi\_100Mbps (Advance Rental)**

**Valid till: 20 Jul 2026**

Number of Connections: 1

Statement Date: 18 Feb 2026

Statement Period: 17 Jan 2026 to 16 Feb 2026

**Total Available Balance**

**₹-5113.53**

Recharge via  
Airtel Thanks App  
[www.airtel.in/pay](http://www.airtel.in/pay)



Scan & pay via any UPI Apps  
Powered by airtel Payments Bank

Opening Balance	Total Recharges	Credits	This month's charges	Closing Balance
₹-5914.92	- ₹0.00	- ₹0.00	+ ₹801.39	= ₹-5113.53

## This Month's Charges Summary

Services	Connections	Plan Charges	Other Charges	Total
Wi-Fi - 071219068000_wifi	1	₹679.15	₹0.00	₹679.15
Taxes (GST)	-	₹122.24	₹0.00	₹122.24
<b>This month's charges</b>				<b>₹801.39</b>
Opening Balance				₹-5914.92
<b>Closing Balance</b>				<b>₹-5113.53</b>

Total : minus Five Thousand One Hundred Thirteen Rupees and Fifty Three Paise Only

## Bills & Payments Summary

Month	Opening Balance (A)	Total Recharges (B)	Adjustment (C)	This month's charges (D)	Closing Balance (A+B+C+D)
February'26	-5914.92	0.00	0.00	801.39	-5113.53
January'26	-6716.31	0.00	0.00	801.39	-5914.92
December'25	-7517.70	0.00	0.00	801.39	-6716.31
November'25	-8319.09	0.00	0.00	801.39	-7517.70

CC  
Dr. Yuwaraj D. Kale  
M. S. Shalakyá (Ayu)  
B.M. Prncpl Offc

# PREPAID Wi-Fi MONTHLY STATEMENT



Yuwaraj Dhanraj Kale

BMAM PRINCIPAL OFFICE KDK CAMPUS, Nagpur  
Maharashtra 440024 India, KDK CAMPUS  
S, Nandanvan, Nagpur, Nagpur, Maharashtra, 440024  
Nagpur Maharashtra 440024  
Email Address: 1989ayu0170bmam@gmail.com  
Alternate Mobile Number: 8484881844

Your Plan: 799 WiFi\_100Mbps (Advance Rental)  
Valid till: 30 Jul 2026

Number of Connections: 1  
Statement Date: 18 Feb 2026  
Statement Period: 17 Jan 2026 to 16 Feb 2026

Total Available Balance

₹-4450.46

Recharge via  
Airtel Thanks App  
[www.airtel.in/pay](http://www.airtel.in/pay)

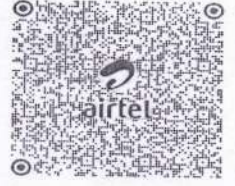

Scan & pay via any UPI Apps  
Powered by airtel Payments Bank

Opening Balance	Total Recharges	Credits	This month's charges	Closing Balance
₹-5251.85	₹0.00	₹0.00	+ ₹801.39	= ₹-4450.46

## This Month's Charges Summary

Services	Connections	Plan Charges	Other Charges	Total
Wi-Fi - 071219067853_wifi	1	₹679.15	₹0.00	₹679.15
Taxes (GST)	-	₹122.24	₹0.0	₹122.24
This month's charges				₹801.39
Opening Balance				₹-5251.85
<b>Closing Balance</b>				<b>₹-4450.46</b>

Total : minus Four Thousand Four Hundred Fifty Rupees and Forty Six Paise Only

## Bills & Payments Summary

Month	Opening Balance (A)	Total Recharges (B)	Adjustment (C)	This month's charges (D)	Closing Balance (A+B+C+D)
February'26	-5251.85	0.0	0.0	801.39	-4450.46
January'26	-6053.24	0.0	0.0	801.39	-5251.85
December'25	-6854.63	0.0	0.0	801.39	-6053.24
November'25	-7656.02	0.0	0.0	801.39	-6854.63

  
Dr. Yuwaraj D. Kale  
M. S. Shalakyá (Ayu)  
Principal  
B.M.A.S. Hospital

# PREPAID Wi-Fi MONTHLY STATEMENT



**Yuvaraj Dhanraj kale**

Bhausahab mulak ayurved,KDK College Road,Darshan Colony,  
Nandanvan, Nagpur, Maharashtra, India,Mahavidyalaya  
nanadevan nagpur,Nagpur,Maharashtra,44002 4  
Nagpur Maharashtra 440024  
Email Address: principalbmam@gmail.com  
Alternate Mobile Number: 8657616813

Your Plan: 799 WiFi\_100Mbps (Advance Rental)

Valid till: 04 Aug 2026

Number of Connections: 1

Statement Date: 03 Feb 2026

Statement Period: 02 Jan 2026 to 01 Feb 2026

**Total Available Balance**

**₹-4929.53**

Recharge via  
Airtel Thanks App  
[www.airtel.in/pay](http://www.airtel.in/pay)

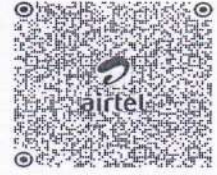

Scan & pay via any UPI Apps  
Powered by airtel Payments Bank

Opening Balance	Total Recharges	Credits	This month's charges	Closing Balance
₹-5730.92	- ₹0.00	- ₹0.00	+ ₹801.39	= ₹-4929.53

This Month's Charges Summary				
Services	Connections	Plan Charges	Other Charges	Total
Wi-Fi - 071220356061_wifi	1	₹679.15	₹0.00	₹679.15
Taxes (GST)	-	₹122.24	₹0.0	₹122.24
<b>This month's charges</b>				<b>₹801.39</b>
Opening Balance	-	-	-	₹-5730.92
<b>Closing Balance</b>				<b>₹-4929.53</b>

Total : minus Four Thousand Nine Hundred Twenty Nine Rupees and Fifty Three Paise Only

Bills & Payments Summary					
Month	Opening Balance (A)	Total Recharges (B)	Adjustment (C)	This month's charges (D)	Closing Balance (A+B+C+D)
February'26	-5730.92	0.0	0.0	801.39	-4929.53
January'26	-6532.31	0.0	0.0	801.39	-5730.92
December'25	-7333.7	0.0	0.0	801.39	-6532.31
November'25	-8135.09	0.0	0.0	801.39	-7333.7

02

Dr. Yuvaraj D. Kale  
M. S. Shalakyā (Ayu)  
Principal  
B. J. S. Ayurvedic College  
Nagpur

Tax Invoice

**VINLAB The Educational Enterprises**

3-3-54/5/1A, Eeshwar Bhawan, Beside Arihant Hotel  
Opp: Bank of India, Kachiguda Station Road  
HYDERABAD-500027  
GSTIN/UIN: 36AKDPG6654P1ZN  
State Name : Telangana, Code : 36  
Contact : 04024659033, 9849236527  
E-Mail : vkg72ln@gmail.com  
www.theeduent.com

Invoice No. GST/25-26/320	e-Way Bill No. 112257809993	Dated <b>6-Nov-25</b>
Reference No. & Date.		Mode/Terms of Payment
Buyer's Order No.		Other References
Terms of Delivery		

Consignee (Ship to)  
**BHAUSAHEB MULAK AYURVED MAHAVIDYALAYA & MEDICAL SCIENCE & RESEARCH HOSPITAL (AYU), GREAT NAG ROAD, NANDANVAN NAGPUR, 440009**  
State Name : Maharashtra, Code : 27

Buyer (Bill to)  
**BHAUSAHEB MULAK AYURVED MAHAVIDYALAYA & MEDICAL SCIENCE & RESEARCH HOSPITAL (AYU), GREAT NAG ROAD, NANDANVAN NAGPUR, 440009**  
State Name : Maharashtra, Code : 27

Sl No.	Description of Goods	HSN/SAC	GST Rate	Quantity	Rate	per	Disc. %	Amount
1	Gynaecological Examination Model	90230010	18 %	1.00 Nos	96,000.00	Nos	40 %	57,600.00
2	Catherterization Trainers(Male & Female)	90230010	18 %	2.00 Nos	21,000.00	Nos	40 %	25,200.00
3	Advanced Full Body CPR Manikin	90230010	18 %	1.00 Nos	96,000.00	Nos	40 %	57,600.00
4	Child CPR	90230010	18 %	1.00 Nos	89,000.00	Nos	40 %	53,400.00
5	Infant CPR	90230010	18 %	1.00 Nos	84,000.00	Nos	40 %	50,400.00
6	MULTIFUNCTIONAL IV TRAINING ARM	90230010	18 %	1.00 Nos	42,000.00	Nos	40 %	25,200.00
7	PEDIATRIC VENIPUNCTURE ARM	90230010	18 %	1.00 Nos	39,000.00	Nos	40 %	23,400.00
8	Breast Examination Model	90230010	18 %	1.00 Nos	26,000.00	Nos	40 %	15,600.00
9	ADVANCED SUTURING MODEL	90230010	18 %	1.00 Nos	96,000.00	Nos	40 %	57,600.00
10	Buttock Injectable Model	9023	18 %	1.00 Nos	21,000.00	Nos	40 %	12,600.00
11	NORMAL DELIVERY MODEL	90230010	18 %	1.00 Nos	36,000.00	Nos	40 %	21,600.00
12	Episiotomy TRAINING SIMUALTOR	90230010	18 %	1.00 Nos	16,000.00	Nos	40 %	9,600.00
13	IUD TRAINER	90230010	18 %	1.00 Nos	9,000.00	Nos	40 %	5,400.00
14	MULTI FUNCTIONAL NURSING FEMALE MANIKIN	90230010	18 %	1.00 Nos	42,000.00	Nos	40 %	25,200.00
15	ADVANCED EAR INSPECTION SIMULATOR	90230010	18 %	1.00 Nos	76,000.00	Nos	40 %	45,600.00
16	ADVANCED OCULAR SIMULATOR OF RETINOTHERPHY	90230010	18 %	1.00 Nos	89,000.00	Nos	40 %	53,400.00
17	ADVANCED EAR INSPECTION SIMULATOR	90230010	18 %	1.00 Nos	67,000.00	Nos	40 %	40,200.00
18	ADVANCED NASAL HEMORRHAGE SIMULATOR	90230010	18 %	1.00 Nos	69,000.00	Nos	40 %	41,400.00
19	Foregin body & HALF BODY CPR	90230010	18 %	1.00 Nos	72,000.00	Nos	40 %	43,200.00
20	GD/H120A, Advanced Nursing & Wound Care Manikin	90230010	18 %	1.00 Nos	1,12,000.00	Nos	40 %	67,200.00

*[Signature]*  
Storekeeper  
B. M. Ayu. Hospital  
Nandanvan, NGP-9

B.M.A.M. NAGPUR  
11-11-25  
7/11/25

continued to page number 2

SUBJECT TO HYDERABAD JURISDICTION

*[Signature]*  
Dr. Yuvaka Kale  
M.S. (Sasanka Ayu)

Tax Invoice(Page 2)

**ational Enterprises**  
 UIN: 36AKDPG6654P1ZN  
 (Bill to)  
**SAHEB MULAK AYURVED MAHAVIDYALAYA**

Invoice No.  
**GST/25-26/320**

Dated  
**6-Nov-25**

No.	Description of Goods	HSN/SAC	GST Rate	Quantity	Rate	per	Disc. %	Amount
21	Mainkin Airway Intubation	9023	18 %	1.00 Nos	42,000.00	Nos	40 %	25,200.00
	<b>IGST Ouput</b>							7,56,600.00
								1,36,188.00
	<b>Total</b>			<b>22.00 Nos</b>				<b>₹ 8,92,788.00</b>

*[Signature]*  
**Storekeeper**  
**B. M. Ayu. Hospital**  
**Nandanvan, NGP-9**

**B.M.A.Y. HOSPITAL NAGPUR**  
 INWARD NO: 922  
 DATE: 7/11/25  
 TIME: 11:00  
 BY: Bmam  
 SECURITY SIGN

Amount Chargeable (in words) **Indian Rupees Eight Lakh Ninety Two Thousand Seven Hundred Eighty Eight Only** E. & O.E

HSN/SAC	Taxable Value	IGST		Total Tax Amount
		Rate	Amount	
90230010	7,18,800.00	18%	1,29,384.00	1,29,384.00
9023	37,800.00	18%	6,804.00	6,804.00
<b>Total</b>	<b>7,56,600.00</b>		<b>1,36,188.00</b>	<b>1,36,188.00</b>

Tax Amount (in words) : **Indian Rupees One Lakh Thirty Six Thousand One Hundred Eighty Eight Only**

**Declaration**  
 We declare that this invoice shows the actual price of the goods described and that all particulars are true and correct.

**Company's Bank Details**  
 A/c Holder's Name : **The Educational Enterprises**  
 Bank Name : **HDFC Bank-0000449**  
 A/c No. : **05622560000449**  
 Branch & IFS Code : **Barkatpura & HDFC0000562**  
 SWIFT Code :

Customer's Seal and Signature \_\_\_\_\_ for The Educational Enterprises  
 Prepared by \_\_\_\_\_ Verified by \_\_\_\_\_



SUBJECT TO HYDERABAD JURISDICTION

*[Handwritten '62']*  
**Dr. Yuvraaj K. K.**  
**M. S. Shalakyā (Ayu)**  
 Principal  
**B.M.A.Y. Hospital**

e-Way Bill

e-Way Bill

Tax Invoice - GST/25-26/320  
6-Nov-25



1. e-Way Bill Details

e-Way Bill No. : 112257809993  
Generated By : 36AKDPG6654P1ZN  
Supply Type : Outward-Supply  
Mode : 1 - Road  
Approx Distance : 520 KM  
Transaction Type : Regular  
Generated Date : 6-Nov-25 3:53 PM  
Valid Upto : 9-Nov-25 11:59 PM

2. Address Details

From

The Educational Enterprises  
GSTIN : 36AKDPG6654P1ZN  
Telangana

Dispatch From

3-3-54/5/1A, Eeshwar Bhawan, Beside Arihant Hotel, Opp: Bank of India, Kachiguda Station Road, HYDERABAD-500027  
HYDERABAD Telangana 500027

To

BHAUSAHEB MULAK AYURVED MAHAVIDYALAYA  
GSTIN :  
Maharashtra

Ship To

& MEDICAL SCIENCE & RESEARCH HOSPITAL (AYU),  
GREAT NAG ROAD, NANDANVAN NAGPUR, 440009  
Maharashtra 440009

3. Goods Details

HSN Code	Product Name & Desc	Quantity	Taxable Amt	Tax Rate (I)
90230010	Gynaecological Examination Model & Gynaecological Examination Model	1 NOS	57,600.00	18
90230010	Catherterization Trainers(Male & Female) & Catherterization Trainers(Male & Female)	2 NOS	25,200.00	18
90230010	Advanced Full Body CPR Manikin & Advanced Full Body CPR Manikin	1 NOS	57,600.00	18
90230010	Child CPR & Child CPR	1 NOS	53,400.00	18
90230010	Infant CPR & Infant CPR	1 NOS	50,400.00	18
90230010	MULTIFUNCTIONAL IV TRAINING ARM & MULTIFUNCTIONAL IV TRAINING ARM	1 NOS	25,200.00	18
90230010	PEDIATRIC VENIPUNCTURE ARM & PEDIATRIC VENIPUNCTURE ARM	1 NOS	23,400.00	18
90230010	Breast Examination Model & Breast Examination Model	1 NOS	15,600.00	18
90230010	ADVANCED SUTURING MODEL & ADVANCED SUTURING MODEL	1 NOS	57,600.00	18
9023	Buttock Injectable Model & 9023	1 NOS	12,600.00	18
90230010	NORMAL DELIVERY MODEL & NORMAL DELIVERY MODEL	1 NOS	21,600.00	18
90230010	Episiotomy TRAINING SIMUALTOR & Episiotomy TRAINING SIMUALTOR	1 NOS	9,600.00	18
90230010	IUD TRAINER & IUD TRAINER	1 NOS	5,400.00	18
90230010	MULTI FUNCTIONAL NURSING FEMALE MANIKIN & MULTI FUNCTIONAL NURSING FEMALE MANIKIN	1 NOS	25,200.00	18
90230010	ADVANCED EAR INSPECTION SIMULATOR & ADVANCED EAR INSPECTION SIMULATOR	1 NOS	45,600.00	18
90230010	ADVANCED OCULAR SIMULATOR OF RETINOTHERPHY & ADVANCED OCULAR SIMULATOR OF RETINOTHERPHY	1 NOS	53,400.00	18
90230010	ADVANCED EAR INSPECTION SIMULATOR & ADVANCED EAR INSPECTION SIMULATOR	1 NOS	40,200.00	18
90230010	ADVANCED NASAL HEMORRHAGE SIMULATOR & ADVANCED NASAL HEMORRHAGE SIMULATOR	1 NOS	41,400.00	18
90230010	Foregin body & HALF BODY CPR & Foregin body & HALF BODY CPR	1 NOS	43,200.00	18
90230010	GD/H120A, Advanced Nursing & Wound Care Manikin & GD/H120A, Advanced Nursing & Wound Care Manikin	1 NOS	67,200.00	18

B.M.A.M. DANDEKAR, NAGPUR  
INWARD NO: 924, DATE: 7/11/25  
TIME: 1:00  
SIGN: B.M.M.

Dr. Yuvaraj D. Kale  
M.S. Shaikya (Ayu)  
Nagpur

continued to page number 2

e-Way Bill

e-Way Bill



No. : Tax Invoice - GST/25-26/320  
Date : 6-Nov-25

1. e-Way Bill Details

e-Way Bill No. : 112257809993	Mode : 1 - Road	Generated Date : 6-Nov-25 3:53 PM
Generated By : 36AKDPG6654P1ZN	Approx Distance : 520 KM	Valid Upto : 9-Nov-25 11:59 PM
Supply Type : Outward-Supply	Transaction Type : Regular	

3. Goods Details

HSN Code	Product Name & Desc	Quantity	Taxable Amt	Tax Rate (%)
9023	Mainkin Airway Intubation & Mainkin Airway Intubation	1 NOS	25,200.00	18

B.M.A.M. HANDEKARAN NAGPUR  
 INWARD NO. 929 DATE 7/11/25  
 TIME: 11:10  
 BY: *[Signature]* SIGN:

Tot. Taxable Amt : 7,56,600.00	Other Amt :	Total Inv Amt : 8,92,788.00
IGST Amt : 1,36,188.00		

4. Transportation Details

Transporter ID :	Doc No. :
Name :	Date :

5. Vehicle Details

Vehicle No. : MH20GC9266	From : HYDERABAD	CEWB No. :
--------------------------	------------------	------------

*02*



C-c-i

# Infologic Techvision LLP

Hospital Software

KAPILA, OFFICE NO 3 & 4, M.S.E.B. ROAD, VISHRAMBAG, SANGLI

Phone No- (0233) 2300206, 9423535290

## AMC Bill

### Customer Copy

Bill No 27 Date 22/12/2025  
Customer Name **BHAUSAHEB MULAK AYURVEDIC COLLEGE, NAGPUR** City NAGPUR  
Product Name AYURSOFT VER 1.0 WEB  
AMC From Date 01/01/2026 AMC To Date 01/01/2027

Words Rs. **Twenty Thousand** Only.

AMC Amount **20000.00**

### BANK DETAILS

BANK NAME: SHRI MAHALAXMI CO-OP BANK LTD.  
IFSC CODE: IBKL0116MCO BRANCH: SANGLI  
ACCOUNT TYPE: CURRENT ACCOUNT NO: 001101010000211  
ACCOUNT NAME: INFOLOGIC TECHVISION LLP



For Infologic Techvision LLP

### Terms and Conditions:

- 1) The terms and conditions mentioned herewith are for current software version terms may change with upgraded software versions.
- 2) compulsory broadband (speed greater then 1mbps) Internet connection is to be provided by the customer for support.
- 3) Working hours 10Am to 6.00Pm. Call registered after 5.000pm will be addressed on next working day. Weekly off on Sunday. Office will remain closed on all government holidays.
- 4) Software provided is property of i-Logic Software Solutions. i-Logic Software Solutions reserves all rights for service provided.
- 5) Please call to 0233 2300206/9423535290 for support and further assistance.No calls on personal mobile numbers of Engineers will be entertained by i-Logic
- 6) Maintenance of data is responsibility of customer. i-Logic software solutions is not responsible for any data loss .Data recovery work if needed will chargeable.
- 7) Subject to Sangli Jurisdiction

09  
Dr. Yuwara D. Kale  
M. S. Shalavé (Ayu)  
Principal  
B.H. ...

29/12/25

प्रति

मा. सचिव

बी.सी. वाय, आर.सी. स्वामिनी  
नागपुर

द्वारा

मा. प्राचार्य

मा. मु. आयुर्वेदिक महाविद्यालय व  
रुग्णालय नंदनवन नागपुर

विषय:- I logic software AMC Bill  
मंजूरीबाबत

मा.

महोदय

मा. मु. आयु. महा. व रुग्णालय येथे

Hospital record चे software I. Logic  
आहे त्याचे AMC Bill 20000 रु. आहे तरी  
मंजूरी देण्यात यावी हि विनंती  
धन्यवाद

आपल्या माहिती स्वरुप सादर

Computer. op.  
Chaitali Gajjar  
Gajjar

Dr. Yuvaraj D. Kale  
M. S. Shalaky (Ayur)  
Principal  
B. M. A. M. Hospital

आपले विश्वासू

डॉ. साविता भास्कर  
Deputy Superintendent  
B. M. A. M. & Hospital

Backward Class Youth Relief Committee's

(Recognised by CCIM & Ayush New Delhi and Affiliated to Maharashtra University of health science Nasik)

# BHAUSAHEB MULAK AYURVED MAHAVIDYALAYA & MEDICAL SCIENCE & RESEARCH HOSPITAL (AYU)

Great Nag Road, Nandanvan, Nagpur - 440 009 Ph. No. : 0712-2712740, 2710727.



**Dr. Mukund S. Dive**

Principal  
B.M.A.M. Nagpur

**Shri Rajendra Mulak**

Secretary  
Ex.-State Minister of Maharashtra  
Finance & Planning, Energy,  
Water Resources, Parliamentary  
Affair & Excise  
Ph. No. 0712-2283815  
2283543 / 2283220

**Smt. Sumanmala Mulak**

Chairman  
K.D.K. College of Engg.  
Umrer College of Engg.  
Nagpur Polytechnic Nagpur  
Bhausaheb Mulak Ayu. College  
& Hospital Nagpur.  
S.R.M. College of Engg. for women

**Outward Letter**

Ref :

No B.M.A.M/854/18  
Date 8-6-2018.

Date : 06/06/2018

**Purchase Order**

## i-Logic Software Solutions.

HQ : Shri Brahmachaitanya  
Near Ganpati Mandir Govt.Colony,  
Vishrambag Sangli 416415.  
Phone No : 0233 2300206,09011210304  
Admin Office : C-407, Jijau Clasic  
Kumbhar wada, Dhayri Pune 411041  
Mobile No : 9422973942

Purchase Order Number

Date:

Dear Sir,

with reference to your quotation, subsequent correspondence and discussion with your representative, it's our pleasure to place this purchase order for software as per given terms and condition stated below

Sr.No	Description	Qty	Rate	Total Amount
1	Ayursoft 2.0 Basic Module Case Paper Registration and OPD Management module with Register Printing, IPD Management with Register Printing	1	50,000	50,000
2	Ayursoft 2.0 Accounting Module Account Management Module for OPD And IPD (Receipt, Payment And Cash book Management)	1	20,000	20,000
3	Ayursoft 2.0 Management Module OT management module with register printing, drug register, Death Register, Delivery Register, Entry modules, Panchkarma Department Management	1	20,000	20,000
4	Ayursoft 2.0 Lab Management Basic And Advanced LAB Reports	1	20,000	20,000

Total

110,000

Rs One Lakh Ten Thousand Only

  
**Dr. Yuwaraj D. Kale**  
M. S. Shalakyia (Ayu)  
Principal  
B.M.A.M. Nagpur.

Terms And Conditions

1) Payment Condition

50% Advance payment along with purchase order and remaining after completion on successful installation.

2) Warranty

1st year free service support from the date of final installation is to be provided by you.

3) Delivery Period

Urgently

4) Others

i) AMC will be charged @ 20% PA ( on PO Value ) is applicable after 1st year & separate confirmation will not require for it.

ii) Software installation CD will be provide by you.

iii) Extra users created will be charged @ Rs 5000/- per user.

We would like to receive an acknowledgement of this order and your acceptance on paper as earliest possible in case you are accepting the said Order.

Accepted Purchase Order	On Behalf Of Management
Dated	
Authorised Signatory	<b>Secretary</b>
Name	<b>Bhauasaheb Mulak Ayurved</b>
Designation	<b>Mahavidyalaya, Nagpur</b>



**Dr. Yuwaraj D. Kale**  
**M. S. Shalakya (Ayu)**  
**Principal**  
**B.M.A.M. Nagpur.**

*All terms as per agreement*  

**i-LOGIC SOFTWARE SOLUTIONS**

KAPILA, OFFICE NO 3 & 4, M.S.E.B. ROAD, VISHRAMBAG, SANGLI

Phone No- (0233) 2300206, 9423535290

**AMC Bill**

**Customer Copy**

**Bill No** 649 **Date** 14/12/2022  
**Customer Name** BHAUSAHEB MULAK AYURVEDIC COLLEGE, NAGPUR **City** NAGPUR  
**Product Name** AMC FOR AYURSOFT WEB DOMAIN RENEWAL **Instalation Date** 14/12/2022  
**AMC From Date** 01/01/2022 **AMC To Date** 01/01/2023  
**Amount** 20000.00

In To Words Rs. Twenty Thousand Only.



**For i-LOGIC SOFTWARE SOLUTIONS**

Dr. Yuwaraj D. Kalr  
M. S. Shalakya (Ayu)  
Principal  
B.M.A.M. Nagpur.

Do Bhausaheb

Bhausaheb  
Deputy Medical Superintendent  
B. M. A. M. & Hospital  
Nandanvan, Nagpur-9



Subject To Sangli Jurisdiction

CREDIT Memo

Customer Copy

### i-LOGIC SOFTWARE SOLUTIONS

SHRI BRAHMACHAITANYA, NEAR GANPATI MANDIR, GOVT CLY, V. BAG SANGLI-416415 Phone:(0233) 2300206

Bill No O-765 Customer Name BHAUSAHEB MULAK AYURVEDIC COLLEGE,NAGPUR  
Date 29/09/2018 NAGPUR

ItemName	Rate	Quantity	Amount
AYURSOFT WEB VER 1.0	55,000.00	1	55,000.00

*(Handwritten signature)*

Dr. Yuwaraj D. Kale  
M. S. Shalakya (Ayu)  
Principal  
B.M.A.M. Nagpur.

E. & O. E. Total 55,000.0

Customer 's Signature

For i-LOGIC SOFTWARE SOLUTIONS

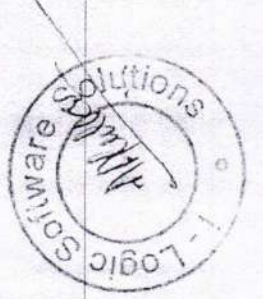



i-Logic Software Solutions

"Shri Brahmachaitanya", Near Ganpati Mandir, Govt. Colony, Vishrambag, Sangli 416415.

Contact No: 0233-2300206 email: ilogicsupport@i-logic.in

web: [www.i-logic.in](http://www.i-logic.in)

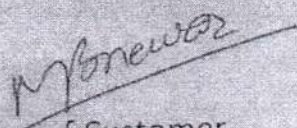
SOFTWARE INSTALLATION DETAILS

Software:	Ayursoft 4.0		
Installation	Single User	Multiuser: 1+4	
Name of party:	Bhausahab Mulak Ayurved Mahavidyala And Hospital		
Address:	Great Nag Road, Nandanvan Nagpur		
Contact Person:	Dr. Dive Sir, Dr. Alnewar, Dr. Bhagadkar	Installation Key:	
Tel No.:	:0712 2712740,		
Reference:	Dr. Dive Sir		
Installed on:	15-06-2018	Installed By: Nitin Kulkarni	
Hardware:	Win 7	Printer: <input checked="" type="checkbox"/>	Internet <input checked="" type="checkbox"/>
Training (Please tick if completed)	1) Demonstration Of Master Data Entry 2) Demo of Sales Bill, Purchase Bill, Purchase Ret, Sales Ret, Bank Entry, Cash Pending and Daily vouchers 3) Day End Process and Backup Process 4) Reports, Ledgers demo		
Confirmation	 Signature of Customer		 Signature of i-Logic Executive

Principal

Bhausahab Mulak Ayurved  
Mahavidyala, Nagpur

  
Dr. Yuwaraj D. Kale  
M. S. Shalakyia (Ayu)  
Principal  
B.M.A.M. Nagpur.

## I-Logic Software Solutions

"Shri Brahmachaitanya", Near Ganpati Mandir, Govt. Colony, Vishrambag, Sangli 416415.

Contact No: 0233-2300206 email: ilogicsupport@i-logic.in

web: [www.i-logic.in](http://www.i-logic.in)

### ORDER FORM

(To be filled at the time of order confirmation)

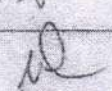
Software:	Ayursoft 4.0			
Installation:	Single User :	Multiuser:1+5		
Name of party:	Bhausahab Mulak Ayurved Mahavidyala And Hospital			
Address:	Great Nag Road, Nandanvan Nagpur			
Contact Person:	Dr. Dive Sir, Dr. Alnewar, Dr. Bhagadkar		Tel No. :0712 2712740,	
email:				
Reference:	Dr. Dive Sir			
Sch. Install Date	15-06-2018			
Price Rs	110,000=00		Discount Rs.	
Yearly Usage Charges	201.		Data Feeding @ Rs	
Payments	Date:	Cheque No:	Amount	Date of deposit
cheque	15/6/18	338	55,000=00	15/6/18
			55,000=00	
Total Cheques	Total Amount			
Name of M.F.E.	Nitin Kulkarni			
	 Sign and Date 15-06-2018			

#### Terms and Conditions:

- 1) On the date of installation, Customer Support Executive will visit your place with prior appointment along with your order form.
- 2) Order once placed cannot be cancelled or transferred.
- 3) Software up gradation required if any are to be told by registered contact person to i-Logic.
- 4) The terms and order details mentioned herewith are for current software version terms may change with upgraded software versions.
- 5) Compulsory 24 x 7 broadband (speed greater than 1Mbps) internet connection is provided by customer for support.
- 6) This software is property of i-Logic Software Solutions and All rights are reserved.
- 7) Yearly Usage charges are compulsory.
- 8) Please call to 0233 2300206, 9423535290 for support and further assistance.

  
**Dr. Yuwaraj D. Kale**  
 M. S. Shalaky (Ayu)  
 Principal  
 B.M.A.M. Nagpur.

### I-LOGIC SOFTWARE SOLUTIONS

SHRI BRAHMACHAITANYA, NEAR GANPATI MANDIR, GOVT CLY, V, BAG SANGLI-416415 Phone:(0233) 2300206

Bill No O-719

Customer Name

BHAUSAHEB MULAK AYURVEDIC COLLEGE, NAGPUR

Date 13/06/2018

NAGPUR

ItemName	Rate	Quantity	Amount
AYURSOFT VER4.0 1) Basic Module 2) Accounting Module 3) OT Module 4) Lab Module	110,000.0	1	110,000.0

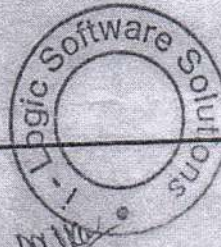

For i-LOGIC SOFTWARE SOLUTIONS

E. & O. E.

Total

110,000.0

*Monewar*

Customer's Signature

Bhausehab Mulak  
Mahavidyalaya, Nagpur

*02*

Dr. Yuwaraj D. Kale  
M. S. Shalaky (Ayu)  
Principal  
B.M.A.M. Nagpur.

**SYNCHRONIK**  
TECH

201, Kamaldutt Residency, Sathe Marg, Dhantoli, Nagpur - 440 012

**INVOICE**

To,  
The Principal,  
Bhausaheb Mulak Ayurved Mahavidyalaya &  
Medical Science & Research Hospital,  
Great Nag Road, Nagpur

Invoice No : 24-25/01  
Invoice Date : 20/04/2024

Bill as per your Purchase Order no Verbal Dated \_\_\_\_\_

Sr. No.	Particulars	Rate	Qty	Amount
1.	Library Automation Software SoftLib Ver 5.3	Rs. 85,000/-	1 No.	Rs. 85,000/-
Discount :				(-) 5,000/-
Total Amount :				Rs. 80,000/-

(Rupees Eighty Thousand Only)  
(All inclusive)

For Synchronik Tech.

*R Bhattad*  
Vaishali R. Bhattad  
[Proprietor]



**Synchronik Tech. Account Details**

Account Name : Synchronik Tech.  
Bank Name : ICICI Bank  
Account Number : 624205021649  
Branch : Ramdaspath, Nagpur  
IFSC Code : ICIC0006242  
GST : Not Applicable.  
PAN : CEUPB9964A

*Dr. Yuwaraj D. Kale*  
M. S. Sihalakya (Ayu)  
Principal  
B.M.A.M. Nagpur.



91 92252 48454

Synchronik.tech@gmail.com

No. Receipt No./83185/2024-25

Dated 15-Oct-24

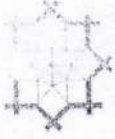

**DELNET- Developing Library Network**  
Jawaharlal Nehru University Campus  
Nelson Mandela Road, Vasant Kunj  
New Delhi-110070  
State Name : Delhi, Code : 07

### Receipt

Received with thanks from : **BHAUSAHEB MULAK AYURVED COLLEGE & RESEARCH HOSPITAL**  
**BMAM, GREAT NAG ROAD, NANDANWAN, NAGPUR**  
**MAHARASHTRA-440024**  
**[DELNET MEM. NO. IM-11038]**

The sum of : **Indian Rupees Nineteen Thousand Four Hundred Seventy Only**

By : **BHAUSAHEB MULAK AYURVED COLLEGE & RESEARCH HOSPITAL, Punjab National Bank (India)**  
Cheque/DD : **CH 624233 25-Sep-24 19,470.00**

Remarks : **AMOUNT RECEIVED TOWARDS ADMISSION FEE & ANNUAL INSTITUTIONAL**  
**MEMBERSHIP FEES FOR THE PERIOD 15.10.2024 - 14.10.2025**

\*\* ₹ 19,470.00/-

\*\*Subject to Realisation

Authenticity

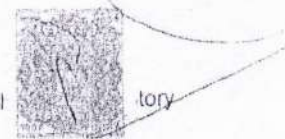

*Ru. Gaur*  
Principal  
Bhausaheb Mulak Ayurved  
Mandadyaya, Nagpur

*65*

**Dr. Yuwaraj D. Kale**  
**M. S. Shalaky (Ayu)**  
Principal  
B.M.A.M. Nagpur.

201, Kamaldutt Residency, Sathe Marg, Dhantoli, Nagpur - 440 012

Certificate of Installation/Delivery

To,  
The Principal,  
Bhauasaheb Mulak Ayurved Mahavidyalaya &  
Medical Science & Research Hospital,  
Great Nag Road, Nagpur

DM No. : STECH/24-25/D/01  
Date : 20/04/2024

As per your work/purchase order no. BMAM/3216/2024 Dated 08/04/2024, the following mentioned software/item is Installed/delivered at your esteemed institution on 20/04/2024

The software/item is working satisfactorily.

Sr. No.	Particulars	Qty
1.	Digital Library Automation DigiSoftLib Ver 5.3 (Unlimited Access Option)	1 No.

Subject to Nagpur Jurisdiction

For Synchronik Tech.

For Bhauasaheb Mulak Ayurved  
Mahavidyalaya & Medical  
Science & Research Hospital

Ashutosh Vidhate  
[Support Executive]

Librarian/Authorized Person

Name of Person

Stamp

  
Dr. Yuwaraj D. Kale  
M. S. Shalaky (Ayu)

  
Principal



+91 92252 48451  
synchronik.tech@gmail.com

Bhauasaheb Mulak Ayurved Mahavidyalaya & Medical Science & Research Hospital

CV

# Invoice Part Paid



Bill No # 2025-2026/11/000239

Date Nov 13, 2025

### Billed By

Techsync Innovations Pvt Ltd  
Eves Garden Mundhwa,  
PUNE-411036,  
Maharashtra, India  
GSTIN: 27AAICT3214E1ZL  
PAN: AAICT3214E  
Email: admin@techsyncinnovations.com  
CIN: U24290PN2020PTC197188

### Billed To

KDK Ayurvedic College  
Nagpur,  
India

Product Details	Amount	CGST	SGST	Total
1. e-Prashasan Software AMC (HSN/SAC: 111)	₹70,000.00	₹6,300.00	₹6,300.00	₹82,600.00
Regarding A.M.C. (Annual Maintenance Charges) of 'e - Prashasan				
NOTE - For the year 2025-2026				

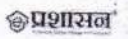

Total (in words) : EIGHTY TWO THOUSAND SIX HUNDRED RUPEES ONLY

Amount	₹70,000.00
CGST	₹6,300.00
SGST	₹6,300.00

### Bank Details

Account Name	TECHSYNC INNOVATIONS PRIVATE LIMITED
Account Number	42698713902
IFSC	SBIN0000316
Account Type	Current
Bank	State Bank of India (SBI)

**Total (INR) ₹82,600.00**

Amount Paid (₹70,000.00)

**Due Amount ₹12,600.00**

*(Handwritten signature)*

Dr. Yuwaraj D. Kale  
M. S. Shalaky (Ayu)  
Principal  
B.M.A.M. Nagpur.



C-vi & C-d.

Dr. Yuwaraj D. Kale  
M. S. S. Patil  
Principal  
B.M.A.M. Nagpur

CG

Digital Library  
Multimedia Section  
LIBRARY

I-CARD  
PLEASE MAINTAIN  
SILENCE

PLAGIARISM SCRUTINY CELL



GPS Map Camera



Google

Nagpur, Maharashtra, India 

Kdk Campus, Nandanvan, Nagpur, Maharashtra  
440024, India

Lat 21.139379° Long 79.128742°

Tuesday, 24/02/2026 04:47 PM GMT +05:30

principalbmam@gmail.com

principalbmam@gmail.com



HOME ABOUT US FACULTY DEPARTMENTS HOSPITAL DETAILS STUDENTS CORNER FACILITIES RESULT COLLEGE DETAILS COMMITTEE IQAC NAAC

FEEDBACK CONTACT US

MUHS Mandate Fee Structure FRA Fee MUHS LINK NCISM LINK

Dr. Yuwaraj D. Kale  
M. S. Shalaky (Ayu)  
Principal  
B.M.A.M. Nagpur.

Handwritten signature in blue ink.

C-2

**B++**  
ACCREDITED  
NAAC

**KDK GROUP OF INSTITUTES**

# ADMISSION OPEN FOR 2025 - 2026

## BAMS

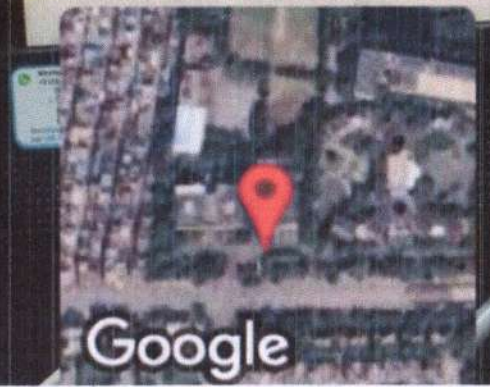

Nagpur, Maharashtra, India

Kdk Campus, Nandanvan, Nagpur, Maharashtra  
440024, India

Lat 21.139467° Long 79.12875°

Wednesday, 25/02/2026 12:19 PM GMT +05:30

### Monthly Status Basic Report ( Month - January 2026)

Name of Staff	1	2	3	4	5	6	7	8	9	10	11	12	13	14	15	16	17	18	19	20	21	22	23	24	25	26	27	28	29	30	31	
Aakansha Sharad Gaigole	P	P	P	H	P	P	P	P	P	P	H	P	P	P	H	P	P	H	P	P	P	P	P	H	H	H	L	L	P	P	P	
Abhijit Ankush Chacharkar	P	P	P	H	P	P	P	P	P	H	H	P	P	P	H	P	P	H	P	P	P	P	P	P	P	H	P	P	P	P	P	
Aditi Wasudeo Chandankhede	P	P	P	H	P	P	P	P	P	P	H	P	P	P	H	P	P	H	P	P	P	P	P	P	P	H	P	P	P	P	P	
Alka Shyam Charde	A	A	H	H	P	P	P	P	P	H	H	P	P	P	H	P	P	H	P	P	P	L	P	P	P	H	P	P	P	P	L	
Anand Nanasheeb Tekade	P	P	P	H	P	P	P	P	P	H	H	P	P	P	H	A	H	H	A	A	P	P	P	P	P	H	P	P	P	P	P	
Ashwini Shrikant Nakade	A	P	P	H	P	P	P	P	P	P	H	P	P	P	H	P	L	H	P	P	P	P	P	P	P	H	A	A	P	P	P	
Avinash Dayaramji Karambhe	P	P	P	H	P	P	P	P	P	H	H	P	P	P	H	P	P	H	P	P	P	P	P	P	P	H	A	P	P	P	P	
Bhairavi Vilas Bante	P	P	P	H	P	P	P	P	P	H	H	P	P	P	H	P	P	H	P	P	P	P	P	P	P	H	P	A	P	P	P	
Bhavana Mangesh Bhalmey	P	L	P	H	P	P	P	P	P	P	H	P	P	P	H	P	P	H	P	P	P	P	P	P	P	P	P	L	L	L	P	
Chhaya Shekhar Tanmane	P	P	P	H	P	P	P	P	P	P	H	P	P	P	P	P	P	H	P	P	P	P	P	P	P	H	L	P	L	L	L	
Diksha Ramkrushna Kapagate	A	A	H	H	P	P	P	P	P	H	H	P	P	P	H	P	P	H	P	P	P	P	P	P	H	H	P	P	P	P	P	
Dipti Kaushalprasad Bopate	P	P	P	H	P	P	P	P	P	H	H	P	L	P	H	P	P	H	P	P	P	P	P	P	P	H	H	P	P	P	P	
Dr. Mahendra Narayandas Agrawal	P	P	H	H	A	P	P	P	P	H	H	P	P	P	H	P	L	H	P	P	P	P	P	P	P	P	A	P	P	L	L	
Dr. Pallavi Diwakar Pawar	L	L	L	H	P	P	P	P	P	H	H	P	P	P	H	P	P	H	P	P	P	P	P	P	P	H	P	P	P	P	P	
Ganesh Suresh Hedao	L	P	P	H	P	P	P	P	P	P	H	P	P	P	H	P	P	H	P	P	P	P	P	P	P	P	P	P	P	P	P	
Gouri Pramod Gothe	A	A	H	H	A	A	A	A	A	H	H	A	A	A	H	A	H	H	A	A	A	P	P	H	H	H	P	P	P	P	P	
Jaya Purushottam Umate	P	A	P	H	P	P	P	P	P	H	H	P	P	P	H	P	L	H	P	P	P	P	P	P	P	H	P	P	P	P	P	
Kavita Dewanand Bhingare	L	P	P	H	P	P	P	P	P	H	H	L	P	P	H	P	P	H	P	P	P	P	P	P	H	H	H	P	P	P	P	
Kshama Amol Dorle	P	L	L	H	P	P	P	P	P	H	P	P	P	P	H	P	P	H	P	P	P	P	P	P	P	H	L	P	P	P	P	
Madhavi Vilas Rehpade	A	A	H	H	P	P	A	P	P	H	H	P	P	P	H	P	P	H	P	P	L	P	P	P	P	H	P	P	P	A	H	
Mamata Pravin Adhao	P	P	P	H	P	P	P	P	P	P	H	P	P	L	H	P	L	H	P	P	P	P	P	P	P	H	P	P	P	P	P	
Mamta Sanjay Talmale	P	P	P	H	P	P	P	P	P	H	H	P	P	P	H	P	H	H	A	A	A	A	A	A	H	H	H	P	P	P	P	
Mangesh Shamrao Kate	P	P	P	H	P	P	P	P	P	H	H	P	P	P	H	P	P	H	P	P	L	L	L	L	H	H	P	P	P	P	P	
Mayuri Arvind Shingnapurkar	P	P	P	H	P	P	P	P	P	P	H	P	P	P	H	P	L	H	P	P	P	P	P	P	P	H	P	P	P	P	P	
Meena Rajabhau Alnewar	P	P	P	H	P	P	P	P	P	P	H	P	P	P	H	P	P	H	L	L	P	P	P	P	P	A	P	P	P	P	P	
Mrunal Dattuji Dange	P	P	P	H	P	P	P	P	P	P	H	P	P	P	H	P	P	H	P	P	P	P	P	P	P	H	A	P	P	A	P	
Navin Vasudev Kuraskar	A	A	H	H	A	P	P	P	P	H	H	P	P	P	H	P	P	H	P	P	P	P	P	P	P	H	P	P	P	P	P	
Nayan Satyam Supare	P	P	P	H	P	P	P	P	P	H	P	P	P	P	H	P	P	H	P	P	P	P	P	P	P	H	H	A	P	P	P	
Nirmala Rajesh Telrandhe	P	P	P	H	P	P	P	P	P	H	H	L	L	L	H	P	P	H	P	P	L	P	P	P	H	P	A	P	P	P	P	
Omprakash Ramkrushna Gulhane	P	P	P	H	P	P	P	P	P	P	H	P	P	P	P	P	P	H	P	P	P	P	P	P	P	H	L	P	P	P	P	
Pallavi Jamnekar	L	P	P	H	P	P	P	P	P	H	H	P	P	L	H	P	P	H	P	P	P	P	P	P	P	H	P	L	P	P	P	
Piyusha Vithal Sarode	P	P	P	H	P	P	P	P	P	H	H	P	P	P	H	P	P	H	L	P	P	P	P	P	P	H	H	P	P	P	P	
Prathmesh Sudhir Vyas	P	P	P	H	P	P	P	P	P	P	P	P	P	P	P	P	P	A	P	P	P	P	P	P	P	H	P	P	P	P	P	
Pravina Sunil Daf	A	A	H	H	A	A	A	A	A	H	H	A	A	A	H	A	H	H	A	A	A	A	A	A	H	H	H	A	A	A	A	H
Prerana Vijay Khedkar	P	P	P	H	P	P	P	P	P	H	H	P	L	P	H	L	L	H	P	P	P	P	P	P	H	P	P	P	P	P	P	
Priti Shankar Chaudhary	A	A	H	H	A	A	A	A	A	H	H	A	A	A	H	A	H	H	A	A	A	A	A	A	H	H	H	A	A	A	A	H
Rajashree Praful Raut	P	P	P	H	P	P	P	P	P	H	H	P	P	P	H	P	P	H	P	A	P	P	P	P	P	H	P	P	P	P	P	
Rajendra Bakaramji Urade	P	L	P	H	P	P	P	P	P	H	H	P	P	P	H	P	P	H	P	P	L	P	P	P	H	P	L	L	L	L	P	P

**Dr. Yuwaraj D. Kale**  
**M. S. Shalakya (Ayu)**  
 Principal  
**B.M.A.M. Nagpur.**



Rewati Anil Rakhunde	A	A	H	H	A	A	A	A	A	H	H	A	A	A	H	A	H	H	A	A	A	A	A	H	H	H	A	A	A	A	H	
Rupali Rajesh Kude	P	L	P	H	P	P	P	P	P	H	H	P	P	P	H	P	P	H	L	L	L	P	P	P	P	H	P	P	L	L	L	
Rupali Suresh Bhanare	P	P	P	H	P	P	P	P	L	H	H	P	P	P	H	P	P	H	P	P	P	P	P	P	P	H	P	P	P	P	P	
Sandeep Kumar Rajak	P	P	P	H	P	P	P	P	P	H	H	P	P	P	H	P	P	H	P	P	P	P	P	P	P	P	P	P	P	P	P	
Sandhya Namdeorao Wagh	P	P	P	H	P	P	P	P	P	H	H	P	P	P	H	P	P	H	P	P	P	P	P	P	P	P	P	P	P	P	P	
Sandhyarani Pradip Ghorude	P	P	P	H	P	P	P	P	P	H	H	A	A	A	H	P	P	H	P	P	P	P	P	P	P	P	H	P	P	P	P	
Sanket Satish Mohata	P	P	P	H	P	P	P	P	P	H	P	P	P	H	P	P	H	P	P	P	P	P	P	P	P	P	H	P	P	P	P	
Sayali Rajkumar Khandelwal	P	P	P	H	A	A	P	P	P	P	H	P	P	P	H	P	P	H	P	P	P	P	A	H	H	H	A	A	P	P	P	
Sharad Durgaprasad Tripathi	A	A	H	H	A	A	A	P	P	H	H	P	P	P	H	P	P	H	P	P	P	P	P	P	P	H	P	P	P	P	P	
Sharayu Sandeep Dingalwar	P	P	P	H	P	A	A	P	A	H	H	P	P	P	H	A	P	H	P	P	P	P	P	P	P	H	P	P	P	P	P	
Shravani Suresh Parate	P	P	P	H	P	P	P	P	P	H	H	P	P	P	H	P	P	H	A	A	A	A	A	H	H	H	A	A	A	A	H	
Shubhangi Sundarsingh Danga	L	P	P	H	P	P	P	P	P	H	P	P	P	H	P	P	H	P	P	P	P	P	P	P	P	H	H	P	P	P	P	
Sneha Sanjay Kubde	P	P	P	H	P	P	P	P	P	H	H	P	P	P	H	P	P	H	P	L	L	L	L	H	H	H	A	P	P	P	P	
Snehal Ramdas Bisen	P	P	P	H	P	P	P	P	P	H	H	P	P	P	H	P	P	H	P	P	P	P	P	P	H	H	H	L	L	L	L	H
Snehal Subhashrao Bhamkar	P	P	P	H	P	P	P	P	P	H	H	P	P	P	H	P	L	H	P	L	P	P	P	H	H	H	L	L	L	L	H	
Sphurti Dnyaneshwar More	P	P	P	H	P	P	P	P	P	H	H	P	P	P	H	P	P	H	P	P	P	P	P	P	P	H	P	P	P	P	P	
Sumi Jain	P	P	P	H	P	P	P	P	P	H	P	P	P	H	P	P	H	P	P	P	P	P	P	P	H	H	A	P	P	P	H	
Sunita Rajesh Paradkar	P	L	L	H	P	P	P	P	P	H	P	P	P	H	P	P	H	P	P	P	P	P	P	P	P	H	L	P	P	P	P	
Suprabha Prakash Tayade	P	P	H	H	P	P	P	P	A	H	H	P	P	A	H	P	P	H	P	A	P	P	P	P	H	P	P	A	A	P	P	
Supriya Dattatray Katkar	P	A	H	H	P	P	P	P	P	H	H	P	P	L	H	P	P	H	P	P	P	P	P	P	H	P	P	P	P	P	P	
Swapnali Sarjerao Patil	P	P	P	H	P	P	P	P	P	H	H	P	P	P	H	P	P	H	P	P	P	P	P	P	H	H	H	P	A	P	P	P
Swatee Atul Dangore	A	P	P	H	P	P	P	P	P	H	H	P	P	P	H	P	P	H	P	P	P	P	P	P	H	H	P	P	P	P	P	
Sweta Nikhil Pandhare	P	P	P	H	P	P	P	P	P	H	H	P	P	P	H	P	L	H	P	P	P	P	P	P	P	H	H	P	P	P	P	
Tejaswini Jeevan Dehankar	P	P	P	H	P	P	P	P	P	H	P	P	P	P	P	P	H	P	P	P	P	P	P	P	H	A	P	P	A	H		
Trupti Maroti Ukey	P	P	P	H	P	P	P	P	P	H	H	P	P	P	H	P	P	H	P	P	P	P	P	P	H	P	L	P	P	P	P	
Ummedishvaramchandra Shamrao Raut	P	P	P	H	P	P	P	P	P	H	H	P	P	P	H	P	P	H	P	P	P	P	P	P	H	P	P	P	P	P	P	
Yogesh Bhauraoji Rewatkar	P	P	P	H	P	P	P	P	P	H	H	P	P	P	H	P	P	H	P	P	P	P	P	P	P	P	P	P	P	P	P	
Yugandhara Nitesh Nasre	P	P	P	H	P	P	P	P	P	H	H	P	P	P	H	P	P	H	P	P	P	P	P	P	H	A	P	P	P	P	P	
Yuwaraj Dhanraj Kale	P	P	P	P	P	P	P	P	P	P	P	P	P	P	P	P	P	P	P	P	P	P	P	P	P	P	L	L	P	P	P	

50

*(Handwritten signature)*

Dr. Yuwaraj D. K.  
M. S. Shalaky (A)  
Principal  
B.M.A.M. Nanded

## Monthly Status Basic Report ( Month - December 2025)

Name of Staff	1	2	3	4	5	6	7	8	9	10	11	12	13	14	15	16	17	18	19	20	21	22	23	24	25	26	27	28	29	30	31
Aakansha Sharad Gaigole	P	P	P	P	P	P	H	P	P	P	P	P	H	H	P	P	P	P	P	P	H	P	P	P	H	P	P	H	P	P	P
Aditi Wasudeo Chandankhede	P	P	P	P	P	P	H	P	P	P	P	P	H	H	P	P	P	P	P	P	H	P	P	P	H	L	H	H	P	P	P
Alka Shyam Charde	P	P	P	P	L	P	H	L	L	L	L	L	L	L	L	L	L	L	P	P	H	P	P	P	H	P	H	H	P	P	L
Anand Nanasahab Tekade	P	P	P	P	P	P	H	P	P	P	P	P	P	H	P	P	P	P	P	P	H	L	P	P	H	P	P	H	L	L	P
Ashwini Shrikant Nakade	P	P	P	P	P	P	H	P	P	P	P	P	H	H	P	P	P	P	P	P	H	P	P	P	H	A	H	H	A	A	A
Avinash Dayaramji Karambhe	P	P	P	P	P	H	H	P	P	P	P	P	H	H	P	P	P	P	P	H	H	P	P	P	H	P	H	H	P	P	P
Bhairavi Vilas Bante	P	P	P	P	P	P	H	P	P	P	P	P	H	H	P	P	P	P	P	P	H	P	P	P	H	P	H	H	P	P	P
Bhavana Mangesh Bhalmey	P	P	L	P	P	P	H	P	P	P	P	P	H	L	L	L	L	L	L	L	L	L	P	P	H	P	H	H	P	P	P
Chhaya Shekhar Tanmane	P	P	P	P	P	H	H	P	P	P	P	P	H	P	A	P	P	P	P	P	H	P	P	P	H	P	P	H	P	P	P
Diksha Ramkrushna Kapagate	A	A	A	A	A	H	H	A	A	A	A	A	H	A	A	A	A	A	A	H	H	A	A	A	H	A	H	H	A	A	A
Dipti Kaushalprasad Bopate	P	P	P	P	P	P	H	P	P	P	P	P	H	H	P	P	P	P	P	P	H	P	P	P	H	P	H	H	P	P	L
Dr. Mahendra Narayandas Agrawal	P	P	P	P	P	P	H	P	P	P	P	P	P	H	P	P	P	P	P	P	H	P	P	P	H	P	H	H	P	P	P
Dr. Pallavi Diwakar Pawar	P	P	P	P	L	L	L	L	L	P	P	P	H	H	A	P	P	P	P	P	H	P	P	P	H	P	H	H	P	P	P
Ganesh Suresh Hedao	P	P	P	P	P	P	H	P	P	P	P	P	P	H	P	P	P	P	P	P	H	P	P	P	H	P	P	H	P	P	P
Jaya Purushottam Umate	P	P	P	P	P	P	H	P	P	P	P	P	H	H	P	P	P	P	A	P	H	P	P	P	H	P	H	H	P	P	P
Kavita Dewanand Bhingare	L	P	L	P	L	P	H	P	P	P	P	P	H	H	P	P	P	P	L	P	H	P	P	P	H	P	H	H	P	P	P
Kshama Amol Dorle	L	P	L	P	P	P	H	P	P	P	P	P	P	H	P	P	P	P	P	P	H	P	P	L	H	A	A	H	A	A	A
Madhavi Vilas Rehpade	P	P	P	P	P	P	H	P	P	P	P	P	H	H	P	P	P	P	P	P	H	P	P	P	H	P	H	H	P	L	P
Mamata Pravin Adhao	L	L	L	L	L	L	L	L	L	L	L	L	L	L	L	L	L	L	L	L	L	L	L	L	L	L	L	L	L	L	L
Mamta Sanjay Talmale	P	P	P	P	P	P	H	P	P	P	P	P	H	H	P	P	P	P	P	P	H	P	P	P	H	P	H	H	P	P	P
Mangesh Shamrao Kate	P	P	P	P	P	P	H	P	P	P	P	P	H	H	P	P	P	P	P	P	H	P	P	P	H	P	H	H	P	P	P
Mayuri Arvind Shingnapurkar	P	P	P	P	P	P	H	P	P	P	P	P	H	H	P	P	P	P	P	P	H	P	P	P	H	L	H	H	P	P	P
Meena Rajabhau Alnewar	P	L	P	L	P	P	H	P	P	P	P	P	H	H	P	P	P	P	P	H	H	P	P	P	H	P	P	H	P	P	P
Mrunal Dattuji Dange	P	P	P	P	P	P	H	P	P	P	P	L	H	H	P	P	P	P	P	P	H	P	P	P	H	P	P	H	P	P	P
Navin Vasudev Kuraskar	P	P	P	A	P	P	H	P	P	P	P	P	P	P	P	A	P	P	P	P	H	P	P	P	H	P	H	H	P	P	A
Nayan Satyam Supare	A	A	A	A	A	H	H	A	A	A	A	A	H	H	P	P	P	A	H	H	A	P	P	H	P	H	P	H	H	P	P
Nirmala Rajesh Telrandhe	L	P	P	P	P	P	H	P	P	P	P	P	P	H	P	P	P	L	L	H	P	P	P	H	L	H	H	P	P	P	
Omprakash Ramkrushna Gulhane	P	P	L	P	P	P	H	P	P	P	P	P	H	L	P	P	P	P	P	H	P	P	P	H	L	H	H	P	P	P	
Pallavi Jamnekar	P	P	P	P	P	H	P	P	P	P	P	P	H	P	P	L	P	P	H	P	P	P	P	H	L	H	H	P	P	P	
Piyusha Vithal Sarode	A	P	P	P	P	P	H	P	P	P	A	H	H	P	P	P	P	P	H	P	P	P	H	A	H	H	H	P	P	P	
Prathmesh Sudhir Vyas	A	A	A	A	A	H	H	A	A	A	A	A	H	H	A	A	A	A	A	H	H	A	A	A	H	A	H	H	A	P	P
Pravina Sunil Daf	A	A	A	A	A	H	H	A	A	A	A	A	H	H	A	A	A	A	A	H	H	A	A	A	H	A	H	H	A	A	A
Prerana Vijay Khedkar	L	L	L	L	L	L	H	P	P	A	A	A	H	H	P	P	P	P	P	P	H	P	P	P	H	P	H	H	P	P	P

**Dr. Yuvraj D. Kale**  
**M. S. Satalakya (Ayu)**  
 Principal  
**B.M.A.M. Nagpur.**

Priti Shankar Chaudhary	A	A	A	A	A	H	H	A	A	A	A	A	H	H	A	A	A	A	H	H	A	A	A	H	A	H	H	A	A	A	
Rajashree Praful Raut	P	P	P	P	P	H	H	P	P	P	P	P	H	H	P	P	A	P	P	P	H	P	P	P	H	P	H	H	P	P	P
Rajendra Bakaramji Urade	P	P	P	P	P	P	H	P	P	P	P	P	H	H	P	P	P	A	A	P	H	P	P	P	H	L	L	H	P	P	P
Rewati Anil Rakhunde	A	A	A	A	A	H	H	A	A	A	A	A	H	H	A	A	A	A	A	H	H	A	A	A	H	A	H	H	A	A	A
Rupali Rajesh Kude	P	P	P	P	P	P	H	P	P	P	P	P	P	H	L	P	P	P	P	P	H	P	P	P	H	L	H	H	P	P	P
Rupali Suresh Bhanare	P	P	P	P	P	P	H	P	P	P	P	P	H	H	P	P	P	P	P	P	H	P	P	P	H	P	H	H	L	L	L
Sandeep Kumar Rajak	P	P	P	P	P	P	H	P	P	P	P	P	P	H	P	P	P	P	P	P	H	P	P	P	H	A	H	H	P	P	P
Sandhya Namdeorao Wagh	P	P	A	A	P	P	H	P	P	P	P	P	H	H	A	A	A	A	A	H	H	A	P	P	H	P	H	H	P	P	P
Sandhyarani Pradip Ghorude	A	A	P	P	P	P	H	P	P	P	P	P	H	H	P	P	P	P	P	P	H	P	A	A	H	P	H	H	P	P	P
Sanket Satish Mohata	P	P	P	P	P	P	H	P	P	P	P	P	H	P	P	P	P	P	P	P	H	P	P	P	H	P	P	H	P	P	P
Sayali Rajkumar Khandelwal	L	L	P	P	P	P	H	P	P	P	P	P	P	H	P	P	P	P	P	P	H	H	P	P	H	L	H	H	P	P	P
Sharad Durgaprasad Tripathi	P	P	P	P	P	P	H	P	P	L	L	L	H	H	P	P	P	P	P	P	H	P	P	P	H	P	H	H	L	L	L
Sharayu Sandeep Dingalwar	P	P	P	P	P	P	H	P	P	P	P	P	H	H	P	P	P	P	P	P	H	A	P	P	H	P	H	H	P	P	P
Shravani Suresh Parate	P	P	P	P	P	P	H	P	P	P	P	P	H	H	P	A	A	P	P	P	H	P	P	P	H	A	H	H	A	A	P
Shubhangi Sundarsingh Danga	P	P	P	P	P	P	H	P	P	P	P	P	H	H	P	P	P	P	P	P	H	P	P	L	H	P	P	H	P	P	P
Sneha Sanjay Kubde	P	L	P	P	P	P	H	P	P	P	P	P	H	P	P	P	P	P	P	H	P	P	L	H	P	H	H	L	L	L	
Snehal Ramdas Bisen	A	A	A	A	A	H	H	P	P	P	P	P	H	H	P	P	P	P	P	P	H	P	A	P	H	A	H	H	P	P	P
Snehal Subhashrao Bhamkar	P	P	P	P	P	P	H	P	P	P	P	P	H	P	P	P	P	P	P	H	P	P	P	H	P	H	H	P	P	P	
Sphurti Dnyaneshwar More	P	P	P	P	P	P	H	P	P	P	P	P	H	H	P	P	P	P	P	L	H	P	P	H	P	H	H	P	P	P	
Sumi Jain	A	A	A	A	A	H	H	P	P	P	P	P	H	H	P	P	P	P	P	P	H	P	P	H	P	H	H	P	P	P	
Sunita Rajesh Paradkar	P	P	P	P	P	P	H	P	P	P	P	P	H	H	P	P	P	P	P	H	P	P	P	H	L	H	H	P	P	P	
Suprabha Prakash Tayade	A	A	P	P	A	P	H	A	P	A	P	P	H	H	P	P	A	A	P	P	H	P	A	A	H	A	H	H	A	A	A
Supriya Dattatray Katkar	P	P	P	P	P	P	H	P	P	P	A	P	H	H	P	P	P	P	P	H	P	P	P	H	A	H	H	A	A	A	
Swapnali Sarjerao Patil	A	A	A	A	A	H	H	A	A	A	A	A	H	H	A	A	A	A	A	H	H	A	A	P	H	A	H	H	P	P	P
Swatee Atul Dangore	P	P	P	P	A	H	H	P	P	P	P	P	H	H	P	P	P	A	P	H	A	P	A	H	A	H	H	P	P	P	
Sweta Nikhil Pandhare	P	P	P	P	P	P	H	P	P	P	P	P	H	H	L	L	P	P	A	H	H	P	P	H	P	H	H	P	P	P	
Tejaswini Jeevan Dehankar	P	P	P	A	P	H	H	P	P	P	P	P	H	H	P	P	A	P	P	P	H	P	P	P	H	A	H	H	P	P	P
Trupti Maroti Ukey	P	P	P	P	P	P	H	P	P	P	P	P	H	P	P	P	P	A	P	H	P	P	P	H	P	H	H	P	P	P	
Ummedishvaramchandra Shamrao Raut	P	P	P	P	P	P	H	P	P	P	P	L	H	H	P	P	P	P	P	H	P	P	A	H	A	H	H	P	P	P	
Vijayashree Bhauraoji Rewatkar	P	P	P	P	P	P	H	P	P	P	P	P	H	P	P	P	P	P	P	H	P	P	P	H	P	H	H	P	P	P	
Vijayashree Nitesh Nasre	P	P	P	P	P	P	H	P	P	P	P	P	H	A	A	A	P	P	P	H	P	P	P	H	P	H	H	P	P	P	
Vijayashree Dhanraj Kale	L	L	P	P	P	P	H	P	P	P	P	P	H	P	P	P	P	P	P	H	P	P	P	H	P	P	H	P	P	P	

B.M.A.M. Nagpur.  
 Principal  
 M. S. Shalakya (Ayu)  
 Dhanraj D. Kale

**GST INVOICE**

C-8

# GYAN SECURITY SOLUTIONS

Original for Buyer

16, SURYODAY NAGAR, BELTARODI ROAD, Near Himalay Empier,  
NAGPUR-440027  
Website : www.gyansecuritysol.in E-Mail : gssolutionsngp@gmail.com  
Phone : 8788373766, 9730511290

**CREDIT**

GSTIN : 27EZYP54949P1ZP

Buyer Name <b>M/s BHAUSAHEB MULAK AYURVED MAHAVIDYALAYA</b> MEDICAL SCIENCE & RESEARCH HOSPITAL (AYU) GREAT NAG ROAD, NANDANVAN, NAGPUR State : 27	Invoice No. : <b>GSS25-26/088</b>	Date : <b>12/08/2025</b>
	P.O. No.:	Date :
PHONE NO. :	D.M. No. :	Date :
GSTIN :	Dispatch Through : <b>BHAUSAHEB MULAK AYURVED</b>	
Shipping Address <b>M/s BHAUSAHEB MULAK AYURVED MAHAVIDYALAYA</b> MEDICAL SCIENCE & RESEARCH HOSPITAL (AYU) GREAT NAG ROAD, NANDANVAN, NAGPUR	SALESMAN : <b>DEB SAHU</b>	
PHONE NO. :	COMPANY BANK DETAIL :- CENTRAL BANK OF INDIA, AYURVED COLLEGE	
GSTIN :	A/C: 5565838307 IFSC: CBIN0283822	

Sr.	PARTICULARS	HSN	GST	QTY.	UNIT	RATE	AMOUNT
1	CP PLUS 4CH NVR CP-UNR-104F1	8521	18	1	PCS	3800.00	3800.00
2	CP PLUS 4MP IP DOME HYBRID UNC-DA41PL3C-L-Y	8525	18	1	PCS	3500.00	3500.00
3	WD 6TB HDD AV PURPLE 3YEARS	8471	18	1	PCS	1950.00	11950.00
4	Camera Installation & Configuration Charges	9987	18	1	NOS	1200.00	1200.00

Total Quantity : 4	Class	SGST		CGST		GROSS AMOUNT	20450.00
	GST %	Taxable Amt.	Tax Amt.	Taxable Amt.	Tax Amt.	DISCOUNT	0.00
	5.00%	0.00	0.00	0.00	0.00	CGST Value	1840.50
	12.00%	0.00	0.00	0.00	0.00	SGST Value	1840.50
	18.00%	20450.00	1840.50	20450.00	1840.50	CR/DR NOTE	0.00
	28.00%	0.00	0.00	0.00	0.00		0.00
						ROUND OFF	0.00
Rs. Twenty Four Thousand One Hundred and Thirty One only						<b>GRAND TOTAL</b>	<b>24131.00</b>

Remark : SUBJECT TO NAGPUR JURISDICTION

Terms & Conditions

Our aggregate turnover does not exceed prescribed limit, hence we are not liable to issue Invoice as per Sub Rule 4 Rule 48 of Central Goods & Services Tax Rules 2017

**For GYAN SECURITY SOLUTIONS**

*Sohme*  
**Storekeeper**  
**B. M. Ayu. Hospital**  
**Nandanvan, NGP-9**

BANK QR-CODE



RECEIVER'S SIGNATURE

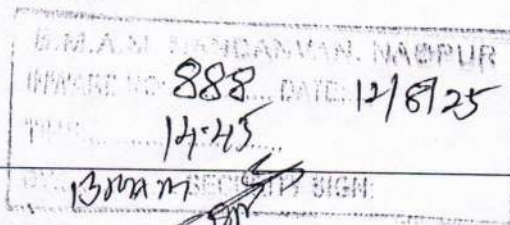

*G S*  
**Dr. Yuwaraj D. Kale**  
**M. S. Shalakyia (Ayu)**  
**Principal**  
**B.M.A.M. Nagpur.**